

ECMA

Standardizing Information and Communication Systems

---

---

---

**Private Telecommunication  
Networks (PTN) - Specification,  
Functional Models and  
Information Flows -  
Name Identification  
Supplementary Services**

---

---



ECMA

Standardizing Information and Communication Systems

---

---

---

**Private Telecommunication  
Networks (PTN) - Specification,  
Functional Models and  
Information Flows -  
Name Identification  
Supplementary Services  
(NISD)**

---

---



## **Brief history**

This Standard is one of a series of ECMA standards defining services and signalling protocols applicable to Private Telecommunication Networks (PTNs). The series uses the ISDN concepts as developed by the ITU-T and is also within the framework of standards for open systems interconnection as defined by ISO. It has been produced under ETSI IMCC work item DE/ECMA-00005.

This particular Standard specifies the Calling Name Identification Presentation, the Connected Name Identification Presentation and the Calling/Connected Name Identification Restriction supplementary services.

This Standard is based upon the practical experience of ECMA member companies and the results of their active and continuous participation in the work of ISO/IEC JTC1, ITU-T, ETSI and other international and national standardization bodies. It represents a pragmatic and widely based consensus.

Compared to the 1st Edition of Standard ECMA-163 (published by ECMA in March 1992), various changes have been made in order to achieve alignment with ETS 300 237 (which is based on the 1st Edition of ECMA-163 but modified during Public Enquiry and published by ETSI in June 1993).



## Table of contents

	<b>Page</b>
<b>1 Scope</b>	1
<b>2 Conformance</b>	1
<b>3 References</b>	1
<b>4 Definitions</b>	2
4.1 External definitions	2
4.2 Additional Network Feature	2
4.3 Application identifier	2
4.4 Busy	2
4.5 Busy party name	2
4.6 Call, basic call	2
4.7 Calling party name	3
4.8 Connected party name	3
4.9 Called party name	3
4.10 Name	3
<b>5 List of acronyms</b>	3
<b>6 SS-CNIP Stage 1 description</b>	3
6.1 Description	3
6.1.1 General description	3
6.1.2 Qualifications on applicability to telecommunication services	3
6.2 Procedures	3
6.2.1 Provision/withdrawal	3
6.2.2 Normal procedures	3
6.2.3 Exceptional procedures	4
6.3 Interactions with other supplementary services	4
6.3.1 Connected Name Identification Presentation (CONP)	4
6.3.2 Calling/Connected Name Identification Restriction (CNIR)	4
6.3.3 Calling Line Identification Presentation (CLIP)	4
6.3.4 Connected Line Identification Presentation (COLP)	4
6.3.5 Calling/Connected Line Identification Restriction (CLIR)	4
6.4 Interworking considerations	4
6.4.1 Incoming calls	4
6.4.2 Outgoing calls	4
6.5 Overall SDL	4
<b>7 SS-CONP Stage 1 description</b>	6
7.1 Description	6
7.1.1 General description	6
7.1.2 Qualifications on applicability to telecommunication services	6

7.2 Procedures	6
7.2.1 Provision/withdrawal	6
7.2.2 Normal procedures	6
7.2.3 Exceptional procedures	6
7.3 Interactions with other supplementary services	7
7.3.1 Calling Name Identification Presentation (CNIP)	7
7.3.2 Calling/Connected Name Identification Restriction (CNIR)	7
7.3.3 Calling Line Identification Presentation (CLIP)	7
7.3.4 Connected Line Identification Presentation (COLP)	7
7.3.5 Calling/Connected Line Identification Restriction (CLIR)	7
7.4 Interworking considerations	7
7.4.1 Outgoing calls	7
7.4.2 Incoming calls	7
7.5 Overall SDL	7
<b>8 SS-CNIR Stage 1 description</b>	<b>9</b>
8.1 Description	9
8.1.1 General description	9
8.1.2 Qualifications on applicability to telecommunication services	9
8.2 Procedures	9
8.2.1 Provision/withdrawal	9
8.2.2 Normal procedures	9
8.2.3 Exceptional procedures	9
8.3 Interactions with other supplementary services	10
8.3.1 Calling Name Identification Presentation (CNIP)	10
8.3.2 Connected Name Identification Presentation (CONP)	10
8.3.3 Calling Line Identification Presentation (CLIP)	10
8.3.4 Connected Line Identification Presentation (COLP)	10
8.3.5 Calling/Connected Line Identification Restriction (CLIR)	10
8.4 Interworking considerations	10
8.4.1 Incoming calls	10
8.4.2 Outgoing calls	10
8.5 Overall SDL	10
<b>9 SS-CNIP Stage 2 description</b>	<b>13</b>
9.1 Functional model	13
9.1.1 Functional model description	13
9.1.2 Description of functional entities	13
9.1.3 Relationship of functional model to basic call functional model	13
9.2 Information flows	13
9.2.1 Definition of information flows	13
9.2.2 Relationship of information flows to basic call information flows	14
9.2.3 Information flow sequences	14
9.3 Functional entity actions	15
9.4 Functional entity behaviour	15
9.5 Allocation of functional entities to physical locations	18



<b>10 SS-CONP Stage 2 description</b>	18
10.1 Functional model	18
10.1.1 Functional model description	18
10.1.2 Description of functional entities	19
10.1.3 Relationship of functional model to basic call functional model	19
10.2 Information flows	19
10.2.1 Definition of information flows	19
10.2.2 Relationship of information flows to basic call information flows	22
10.2.3 Information flow sequences	22
10.3 Functional entity actions	22
10.4 Functional entity behaviour	24
10.5 Allocation of functional entities to physical locations	27
<b>11 SS-CNIR Stage 2 description</b>	27
11.1 Functional model	27
11.1.1 Functional model description	27
11.1.2 Description of functional entities	28
11.1.3 Relationship of functional model to basic call functional model	28
11.2 Information flows	28
11.2.1 Definition of information flows	28
11.2.2 Relationship of information flows to basic call information flows	28
11.2.3 Information flow sequences	29
11.3 Functional entity actions	29
11.4 Functional entity behaviour	29
11.5 Allocation of functional entities to physical locations	29
<b>Annex A (normative) Structure and content of a PTN name</b>	33



## 1 Scope

This Standard specifies the supplementary services Calling Name Identification Presentation (SS-CNIP), Connected Name Identification Presentation (SS-CONP) and Calling/Connected Name Identification Restriction (SS-CNIR), which are applicable to various basic services supported by Private Telecommunication Networks (PTNs). Basic services are specified in ETS 300 171.

Calling Name Identification Presentation (SS-CNIP) is a supplementary service which is offered to the called user and which provides the name of the calling user (calling party name) to the called user.

Connected Name Identification Presentation (SS-CONP) is a supplementary service which is offered to the calling user and which provides to the calling user the following:

- the name of the user who answers the call (connected party name),
- optionally the name of the alerting user (called party name),
- optionally the name of the called user who cannot be reached (busy party name).

Calling/Connected Name Identification Restriction (SS-CNIR) is a supplementary service which is offered to a user to restrict presentation of that user's name to another user.

Provision of a user's name to the PTN is outside the scope of this Standard.

Service specifications are produced in three stages, according to the method described in ENV 41005.

This Standard contains the stage 1 and 2 specifications of the Name Identification supplementary services. The stage 1 specifications specify the supplementary services as seen by users of PTNs. The stage 2 specifications identify the functional entities involved in the supplementary services and the information flows between them.

## 2 Conformance

In order to conform to this Standard, a stage 3 standard shall specify signalling protocols and equipment behaviour that are capable of being used in a PTN which supports the supplementary service(s) specified in this Standard. This means that, to claim conformance, a stage 3 standard is required to be adequate for the support of those aspects of the stage 1 and stage 2 clauses for that supplementary service which are relevant to the interface or equipment to which the stage 3 standard applies.

These stage 1 and stage 2 clauses for the Calling Name Identification Presentation supplementary service are clauses 6 and 9 respectively.

These stage 1 and stage 2 clauses for the Connected Name Identification Presentation supplementary service are clauses 7 and 10 respectively.

These stage 1 and stage 2 clauses for the Calling/Connected Name Identification Restriction supplementary service are clauses 8 and 11 respectively.

## 3 References

- |                  |  |
|------------------|--|
| ETS 300 171      | Private Telecommunication Network (PTN); Specification, functional models and information flows; Control aspects of circuit mode basic services (1992) |
| ISO 8859-1       | Information processing - 8-bit single-byte coded graphic character sets - Part 1: Latin alphabet No. 1 (1987)  |
| ENV 41005        | Method for the specification of basic and supplementary services of private telecommunication networks (1990)  |
| ENV 41007        | Definition of terms in private telecommunication networks (1989)   |
| CCITT Rec. I.112 | Vocabulary of terms for ISDNs (1988)   |
| CCITT Rec. I.210 | Principles of telecommunication services supported by an ISDN and the means to describe them (1988)  |
| CCITT Rec. T.61  | Character repertoire and coded character sets for the international teletex service (1988)   |
| CCITT Rec. Z.100 | Specification and description language (1988)  |

## 4 Definitions

For the purpose of this Standard the following definitions apply.

### 4.1 External definitions

This Standard uses the following terms defined in other documents:

- Basic Service (CCITT Rec. I.210)
- Connection (CCITT Rec. I.112)
- Integrated Services Digital Networks (CCITT Rec. I.112)
- Private (ENV 41007)
- Private Telecommunication Network Exchange (ENV 41007)
- Public (ENV 41007)
- Public ISDN (ENV 41007)
- Service (CCITT Rec. I.112)
- Signalling (CCITT Rec. I.112)
- Supplementary Service (CCITT Rec. I.210)
- Telecommunication Network (ENV 41007)
- Terminal, Terminal equipment (ENV 41007)
- User (ETS 300 171)

This Standard refers to the following basic call functional entities defined in ETS 300 171:

- Call Control
- Call Control Agent

This Standard refers to the following basic call inter-FE relationships defined in ETS 300 171:

- r1
- r2

This Standard refers to the following basic call information flows defined in ETS 300 171:

- DISCONNECT request/indication
- REPORT request/indication
- RELEASE request/indication
- SETUP request/indication
- SETUP response/confirmation
- SETUP REJECT request/indication

### 4.2 Additional Network Feature

A capability, over and above that of a basic service, provided by a PTN, but not directly to a PTN user.

### 4.3 Application identifier

Manufacturer-specific information that can accompany a name and imply the structure of the name (see annex A).

### 4.4 Busy

An ISDN destination is considered to be busy if either a "network determined user busy" or a "user determined user busy" conditions occurs.

### 4.5 Busy party name

The name of the called user who cannot be reached because of a busy condition.

### 4.6 Call, basic call

An instance of the use of a basic service.

**4.7 Calling party name**

The name of the calling user.

**4.8 Connected party name**

The name of the user who answers the call.

**4.9 Called party name**

The name of the alerting user.

**4.10 Name**

A string of maximum 50 characters which is used for the name identification of the PTN user of a call.

*NOTE 1*

*The structure and content of a name are defined in annex A.*

**5 List of acronyms**

CC	Call Control (functional entity)
CCA	Call Control Agent (functional entity)
CONP	Connected Name Identification Presentation
CNIP	Calling Name Identification Presentation
CNIR	Calling/Connected Name Identification Restriction
FE	Functional Entity
ISDN	Integrated Services Digital Network
PTN	Private Telecommunication Network
PTNX	Private Telecommunication Network Exchange
SDL	Specification and Description Language
SS-CONP	Connected Name Identification Presentation supplementary service
SS-CNIP	Calling Name Identification Presentation supplementary service
SS-CNIR	Calling/Connected Name Identification Restriction supplementary service
TE	Terminal Equipment

**6 SS-CNIP Stage 1 description**

**6.1 Description**

**6.1.1 General description**

Calling Name Identification Presentation (SS-CNIP) is a supplementary service which is offered to the called user and which provides the name of the calling user (calling party name) to the called user.

The PTN provides the calling party name to the called user when an incoming call is presented.

The possible provision of the calling party name by the calling user to the PTN is outside the scope of this Standard.

**6.1.2 Qualifications on applicability to telecommunication services**

This supplementary service is applicable to all basic telecommunication services.

**6.2 Procedures**

**6.2.1 Provision/withdrawal**

SS-CNIP shall be generally available. There is no need for service profile control.

Some users may have a service profile which permits the override of calling name identification restriction.

**6.2.2 Normal procedures**

**6.2.2.1 Activation/Deactivation/Registration/Interrogation**

SS-CNIP shall be permanently activated. No information needs to be registered with the PTN for this supplementary service, and therefore interrogation is not applicable.

**6.2.2.2 Invocation and operation**

The PTN shall provide the called user with the calling party name at the same time as indicating an incoming call.

The method by which the PTN obtains the name information is implementation-dependent and outside the scope of this Standard. The management of the PTN name directory system is also outside the scope of this Standard.

### **6.2.3 Exceptional procedures**

#### **6.2.3.1 Invocation and operation**

There are two exceptions when the calling party name shall not be presented to the called user:

- when the calling name identification restriction has been invoked (see definition of the Calling/Connected Name Identification Restriction), and
- when the calling party name is not available, e.g. due to interworking with another network or when no name is registered against the calling PTN user.

In such cases the called user shall receive an indication of the situation.

In some cases where calling name identification restriction has been invoked, there may be certain categories of called user that have the service profile to override this restriction and have the calling party name presented, e.g. emergency stations, PTN operators. In these circumstances, presentation shall include an indication that restriction has been invoked.

### **6.3 Interactions with other supplementary services**

This clause specifies interactions with other supplementary services for which PTN standards were available at the time of publication of this Standard.

#### **6.3.1 Connected Name Identification Presentation (CONP)**

No interactions.

#### **6.3.2 Calling/Connected Name Identification Restriction (CNIR)**

The calling party name shall not be presented if calling name identification restriction has been invoked at the calling user, unless the called user has the service profile to override this restriction.

#### **6.3.3 Calling Line Identification Presentation (CLIP)**

No interactions.

#### **6.3.4 Connected Line Identification Presentation (COLP)**

No interactions.

#### **6.3.5 Calling/Connected Line Identification Restriction (CLIR)**

No interactions.

### **6.4 Interworking considerations**

#### **6.4.1 Incoming calls**

On calls incoming from another network, the calling party name shall be obtained from the other network if available. Where no name is provided by the other network, the called PTN user shall be given an indication "name unavailable" or "presentation restricted", as appropriate.

#### **6.4.2 Outgoing calls**

On outgoing calls to another network, the PTN shall provide the calling party name to the other network if this network supports an equivalent supplementary service and if the name is available and presentation not restricted.

### **6.5 Overall SDL**

Figure 1 contains the dynamic description of SS-CNIP using the SDL defined in CCITT Rec. Z.100. The SDL process represents the behaviour of the network in providing SS-CNIP. The relationship to the basic call process is indicated in the annotations.

Output signals to the right represent primitives to the called PTN user. Input signals from the left represent internal stimuli.

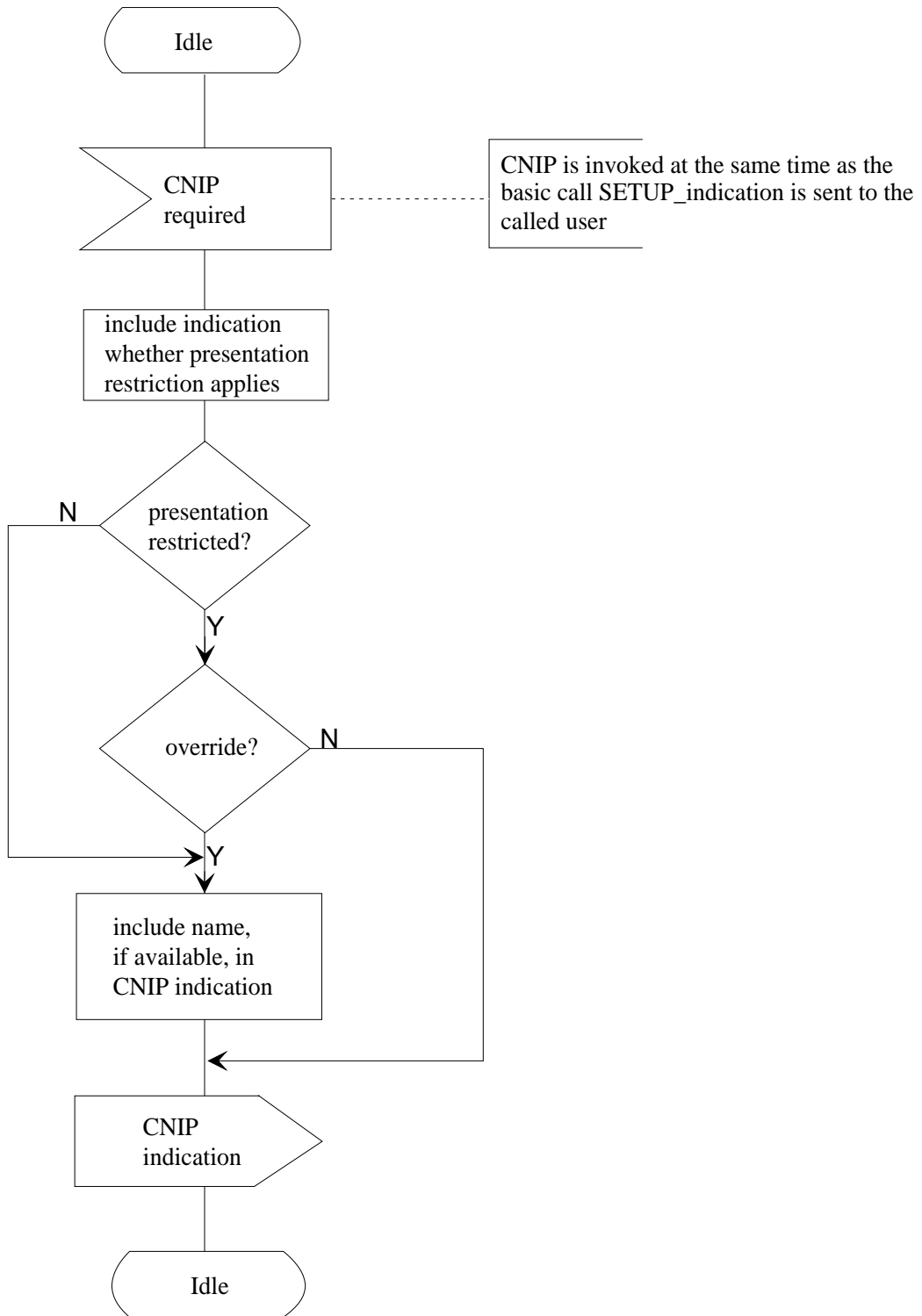

ECMA-94-0052-A

Figure 1 - SS-CNIP overall SDL

## **7 SS-CONP Stage 1 description**

### **7.1 Description**

#### **7.1.1 General description**

Connected Name Identification Presentation (SS-CONP) is a supplementary service which is offered to the calling user and which provides to the calling user the following:

- the name of the user who answers the call (connected party name),
- optionally the name of the alerting user (called party name),
- optionally the name of the called user who cannot be reached (busy party name).

The PTN provides the connected party name to the calling user when the called user connects to the incoming call. The PTN optionally provides the busy party name to the calling user when the called user is busy. The PTN optionally provides the called party name to the calling user when the called user is alerting.

#### *NOTE 2*

*Interactions with certain supplementary services may cause the connected party name to differ from the called party name.*

The possible provision of the connected party name by the connected user to the PTN is outside the scope of this Standard.

#### **7.1.2 Qualifications on applicability to telecommunication services**

This supplementary service is applicable to all basic telecommunication services.

### **7.2 Procedures**

#### **7.2.1 Provision/withdrawal**

SS-CONP shall be generally available. There is no need for service profile control.

Some users may have a service profile which permits the override of connected/called/busy name identification restriction.

#### **7.2.2 Normal procedures**

##### **7.2.2.1 Activation/Deactivation/Registration/Interrogation**

SS-CONP shall be permanently activated. No information needs to be registered with the PTN for this supplementary service, and therefore interrogation is not applicable.

##### **7.2.2.2 Invocation and operation**

The PTN shall provide the calling user with the connected party name at the same time as indicating that call establishment is complete. The PTN may provide the calling user with the busy party name at the same time as indicating that call establishment is unsuccessful. The PTN may provide the calling user with the called party name at the same time as indicating that the call is alerting.

The method by which the PTN obtains the name information is implementation-dependent and outside the scope of this Standard. The management of the PTN name directory system is also outside the scope of this Standard.

#### **7.2.3 Exceptional procedures**

##### **7.2.3.1 Invocation and operation**

There are two exceptions when the connected/called/busy party name shall not be presented to the calling user:

- when the connected/called/busy name identification restriction has been invoked (see definition of Calling/Connected Name Identification Restriction), and
- when the connected/called/busy party name is not available, e.g. due to interworking with another network or when no name is registered against the destination PTN user.

In such cases the calling user shall receive an indication of the situation.



In some cases where Connected Name Identification Restriction has been invoked, there may be certain categories of calling user that have the service profile to override this restriction and have the connected/called/busy party name presented, e.g. emergency stations, PTN operators. In these circumstances, presentation shall include an indication that restriction has been invoked.

### **7.3 Interactions with other supplementary services**

This clause specifies interactions with other supplementary services for which PTN standards were available at the time of publication of this Standard.

#### **7.3.1 Calling Name Identification Presentation (CNIP)**

No interactions.

#### **7.3.2 Calling/Connected Name Identification Restriction (CNIR)**

The connected/called/busy party name shall not be presented if Connected Name Identification Restriction has been invoked at the destination user, unless the calling user has the service profile to override this restriction.

#### **7.3.3 Calling Line Identification Presentation (CLIP)**

No interactions.

#### **7.3.4 Connected Line Identification Presentation (COLP)**

No interactions.

#### **7.3.5 Calling/Connected Line Identification Restriction (CLIR)**

No interactions.

### **7.4 Interworking considerations**

#### **7.4.1 Outgoing calls**

On calls outgoing to another network, the connected/called/busy party name shall be obtained from the other network if available. Where no name is provided by the other network, the calling PTN user shall be given an indication "name unavailable" or "presentation restricted", as appropriate.

#### **7.4.2 Incoming calls**

On incoming calls from another network, the PTN shall provide the connected/called/busy party name to the other network if this network supports an equivalent supplementary service and if the name is available and presentation not restricted.

### **7.5 Overall SDL**

Figure 2 contains the dynamic description of SS-CONP using the SDL defined in CCITT Rec. Z.100. The SDL process represents the behaviour of the network in providing SS-CONP. The relationship to the basic call process is indicated in the annotations.

Output signals to the left represent primitives to the calling PTN user. Input signals from the right represent internal stimuli.

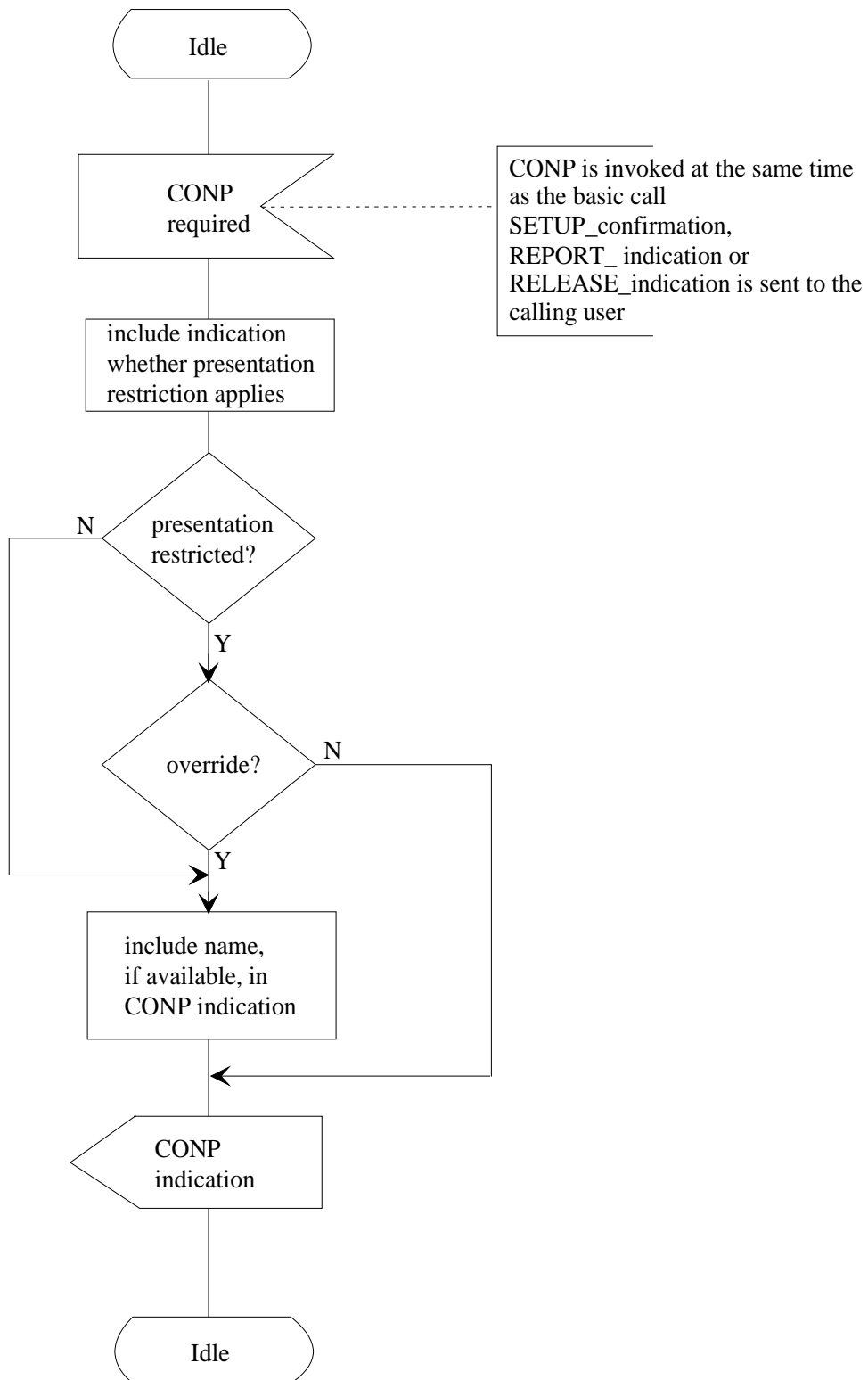

ETMA-94-0053-A

Figure 2 - SS-CONP overall SDL

## **8 SS-CNIR Stage 1 description**

### **8.1 Description**

#### **8.1.1 General description**

Calling/Connected Name Identification Restriction (SS-CNIR) is a supplementary service which is offered to a user to restrict presentation of that user's name to another user.

When SS-CNIR applies to a user, the user's name is normally not presented to any other user.

#### **8.1.2 Qualifications on applicability to telecommunication services**

The supplementary service is applicable to all basic telecommunication services.

### **8.2 Procedures**

#### **8.2.1 Provision/withdrawal**

SS-CNIR shall be provided on a service profile basis. A PTN may provide one or more of several service options. The options shall apply separately to each name. The following service profile options are available.

- SS-CNIR mode:
  - permanent (invoked for all calls)
  - temporary (specified by user per call)
- Default for temporary mode:
  - presentation restricted
  - presentation not restricted

#### **8.2.2 Normal procedures**

##### **8.2.2.1 Activation/Deactivation/Registration/Interrogation**

SS-CNIR shall be activated on provision and deactivated on withdrawal. This supplementary service requires no registration and admits no interrogation.

##### **8.2.2.2 Invocation and operation**

If permanent mode is provided, identification restriction shall be invoked automatically for all calls originating or terminating at the PTN user concerned.

If temporary mode is provided, the called party name and busy name shall not be presented. If temporary mode with default "presentation restricted" is provided, identification restriction of the calling party name and connected party name shall be invoked automatically for all calls originating or terminating at the PTN user concerned, unless requested otherwise by the PTN user at call establishment time. If temporary mode with default "presentation not restricted" is provided, identification restriction of the calling party name and connected party name shall not be invoked automatically for calls originating or terminating at the PTN user concerned, unless requested otherwise by the PTN user at call establishment time.

To override the default for an outgoing call when temporary mode is provided, the calling user makes a request for restriction or no restriction at the same time as requesting call establishment. To override the default for an incoming call when temporary mode is provided, the called user makes a request for restriction or no restriction at the same time as responding to the incoming call indication.

If identification restriction is invoked for an outgoing call, the calling party name shall be marked by the PTN as "presentation restricted". This prevents presentation to the called user (unless the called user has an override service profile).

If identification restriction is invoked for an incoming call, the connected/called/busy party name shall be marked by the PTN as "presentation restricted". This prevents presentation to the calling user (unless the calling user has an override service profile).

#### **8.2.3 Exceptional procedures**

##### **8.2.3.1 Invocation and operation**

A request from the PTN user for the override of a default shall be ignored if the PTN user is not provided with the temporary mode.

### **8.3 Interactions with other supplementary services**

This clause specifies interactions with other supplementary services for which PTN standards were available at the time of publication of this Standard.

#### **8.3.1 Calling Name Identification Presentation (CNIP)**

See SS-CNIP clause 6.3.2.

#### **8.3.2 Connected Name Identification Presentation (CONP)**

See SS-CONP clause 7.3.2.

#### **8.3.3 Calling Line Identification Presentation (CLIP)**

No interactions.

#### **8.3.4 Connected Line Identification Presentation (COLP)**

No interactions.

#### **8.3.5 Calling/Connected Line Identification Restriction (CLIR)**

No interactions.

### **8.4 Interworking considerations**

#### **8.4.1 Incoming calls**

This PTN supplementary service does not apply to the calling user of an incoming call. The other network may provide the equivalent service, in which case the PTN may receive an indication that presentation of the calling party name is restricted. In such a situation the other network may or may not supply the calling party name to the PTN. If not provided, even a called PTN user with an override service profile will be given only an indication that presentation is restricted. If the called user has invoked name identification restriction, the connected/called/busy party name is marked as "presentation restricted". This indication shall be passed on to the other network.

#### **8.4.2 Outgoing calls**

This PTN supplementary service does not apply to the connected user of an outgoing call. The other network may provide the equivalent service, in which case the PTN may receive an indication that presentation of the connected/called/busy party name is restricted. In such a situation the other network may or may not supply the connected/called/busy party name to the PTN. If not provided, even a calling PTN user with an override service profile will be given only an indication that presentation is restricted. If the calling user has invoked name identification restriction, the calling party name shall be marked as "presentation restricted". This indication shall be passed on to the other network.

### **8.5 Overall SDL**

Figure 3 contains the dynamic description of SS-CNIR using the SDL defined in CCITT Rec. Z.100. The SDL process represents the behaviour of the network in providing SS-CNIR. The relationship to the basic call process is indicated in the annotations.

Input signals from the left represent primitives from the served PTN user. Input signals from the right represent internal stimuli.

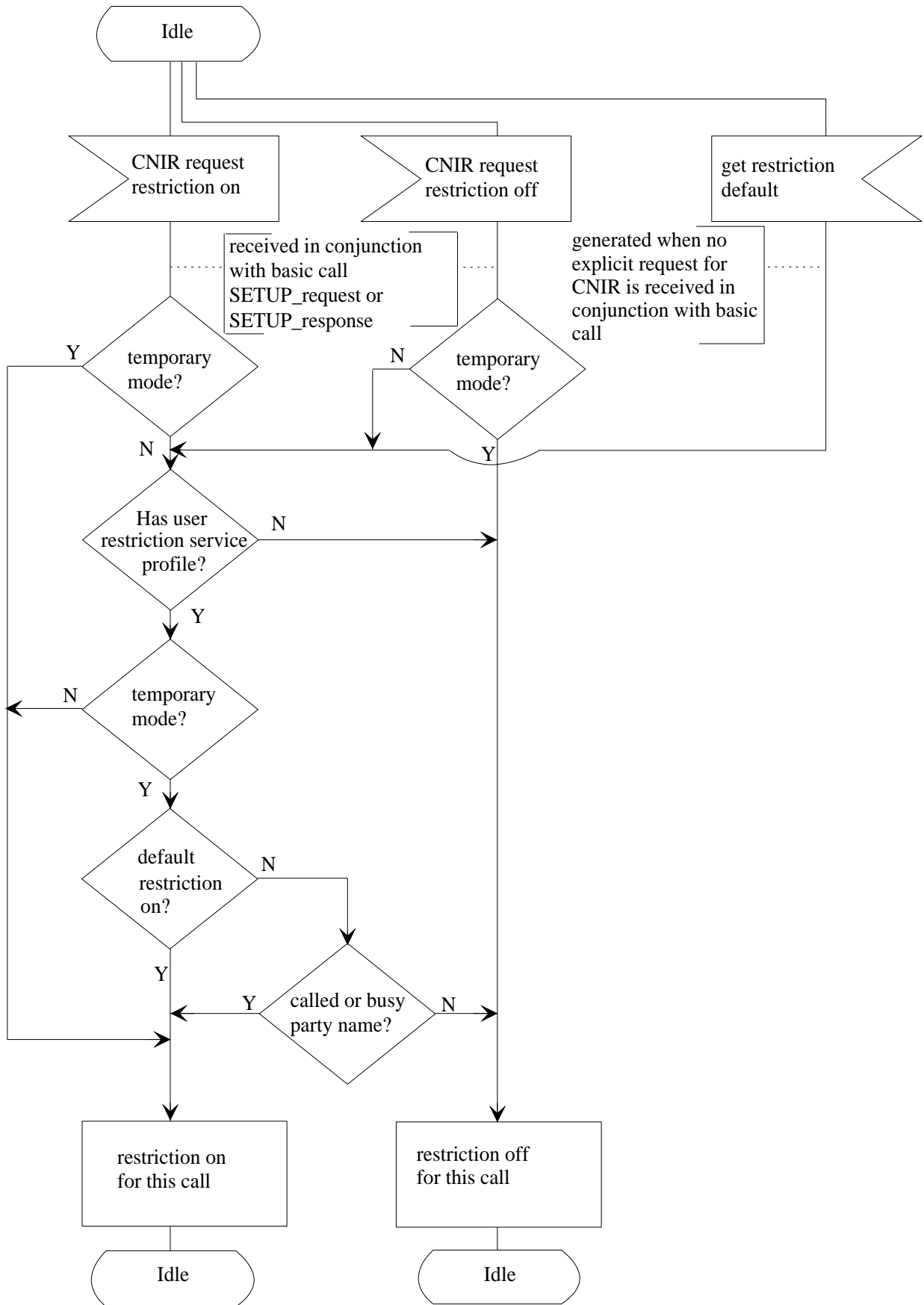

Figure 3 - SS-CNIR overall SDL



## 9 SS-CNIP Stage 2 description

### 9.1 Functional model

#### 9.1.1 Functional model description

The functional model for SS-CNIP shall comprise the FEs "CNIP Provision" (FE1), "CNIP Presentation" (FE2) and "CNIP Reception" (FE3). A relationship ra shall exist between FE1 and FE2 and relationship rb shall exist between FE2 and FE3. Figure 4 shows these FEs and relationships.

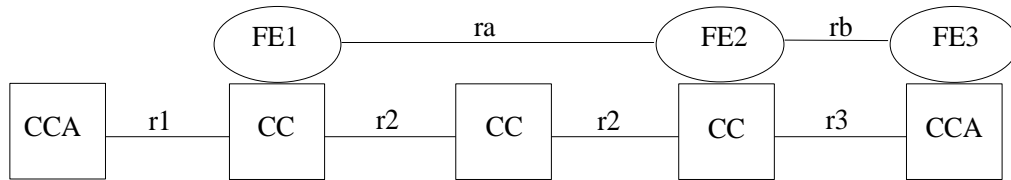

EDMA-94-0055-A

**Figure 4 - Functional model and relationship to basic call for SS-CNIP**

#### 9.1.2 Description of functional entities

The functional entities required by SS-CNIP shall be as follows:

- FE1 CNIP Provision: responsible for provision of the calling party name information and associated indicators to FE2.
- FE2 CNIP Presentation: responsible for reporting the calling party name information and associated indicators to FE3.
- FE3 CNIP Reception: responsible for delivery of the calling party name information and associated indicators to the PTN user.

#### NOTE 3

*The structure of the name information is described in annex A of this Standard.*

#### NOTE 4

*The possibility that the name information is stored in another FE (data base) and provided to FE1 on request for delivery to FE2 is outside the scope of this Standard.*

#### 9.1.3 Relationship of functional model to basic call functional model

Figure 4 also shows the relationship with a basic service for SS-CNIP.

### 9.2 Information flows

#### 9.2.1 Definition of information flows

The information flows INFORM 1 and INFORM 2 shall apply for SS-CNIP.

In the tables below, the column headed "Request" indicates which of the service elements are mandatory (M) and which are optional (O) in a request/indication information flow. The column headed "Confirm" indicates which of the service elements are mandatory (M) and which are optional (O) in a response/confirmation information flow.

##### 9.2.1.1 INFORM 1

This unconfirmed information flow, which conveys the calling party name, shall be sent over relationship ra (optional in the case of name unavailable, otherwise mandatory). It shall contain the service elements listed in table 1.

**Table 1 - Content of INFORM 1**

Service elements	Allowed value	Request	Confirm
Presentation Indicator	presentation not restricted presentation restricted calling party name not available	M	
Name		O (NOTE 5)	
Type of Character Set		O (NOTE 5)	
Application Identifier		O	

*NOTE 5*

*The service element shall be present if and only if the name is available.*

**9.2.1.2 INFORM 2**

This unconfirmed information flow, which conveys the calling party name, shall be sent over relationship rb (optional in the case of name unavailable, otherwise mandatory). It shall contain the service elements listed in table 2.

**Table 2 - Content of INFORM 2**

Service elements	Allowed value	Request	Confirm
Presentation Indicator	presentation not restricted presentation restricted calling party name not available	M	
Name		O (NOTE 6)	
Type of Character Set		O (NOTE 6)	
Application Identifier		O	

*NOTE 6*

*The service element shall be present as indicated if the name is available and not restricted, or if restricted and the called user has an override service profile. Otherwise the service element shall be omitted.*

**9.2.2 Relationship of information flows to basic call information flows**

The SS-CNIP information flow shall be sent at the same time as the basic call information flow SETUP request/indication (r2/r3 in figure 5).

**9.2.3 Information flow sequences**

Signalling procedures shall be provided in support of the information flow sequences specified below. In addition, signalling procedures shall be provided to cover other sequences arising from error situations, interactions with basic call, interactions with other supplementary services, different topologies, etc..

In figure 5, SS-CNIP information flows are represented by solid arrows and basic call information flows are represented by broken arrows. An ellipse embracing two information flows indicates that the two information flows occur together. Within a column representing an SS-CNIP functional entity, the numbers refer to functional entity actions listed in 9.3.

Figure 5 shows the information flow sequence for normal operation of SS-CNIP.



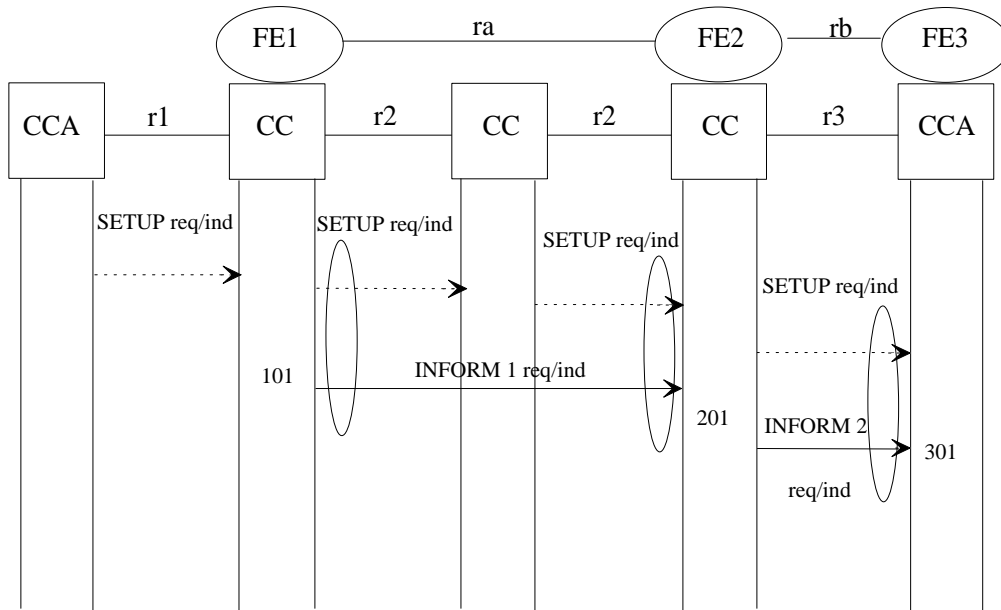

ETMA-94-0058-A

**Figure 5 - Information flow sequence for SS-CNIP**

### 9.3 Functional entity actions

The following FE actions shall occur at the points indicated in figure 5:

– **FE1 action 101:**

Generate INFORM 1 request/indication (if available) and send it at the same time as the basic call SETUP request/indication to the subsequent functional entity FE2.

– **FE2 action 201:**

Receive INFORM 1 request/indication, remove the name information according to element Presentation Indicator and the override service profile of the called user and send INFORM 2 at the same time as the basic call SETUP request/indication to the functional entity FE3.

– **FE3 action 301:**

Receive INFORM 2 request/indication and provide the received information to the called PTN user.

### 9.4 Functional entity behaviour

Figures 6, 7 and 8 are intended to illustrate typical FE behaviour in terms of information flows sent and received. The figures show the behaviour of the functional entities FE1, FE2 and FE3 in providing SS-CNIP using the SDL defined in CCITT Rec. Z.100.

Output signals to the right represent information flows to other functional entities or primitives to the called PTN user. Input signals from the left represent information flows from other functional entities or internal stimuli. The relationship to the basic call process is indicated in the annotations.

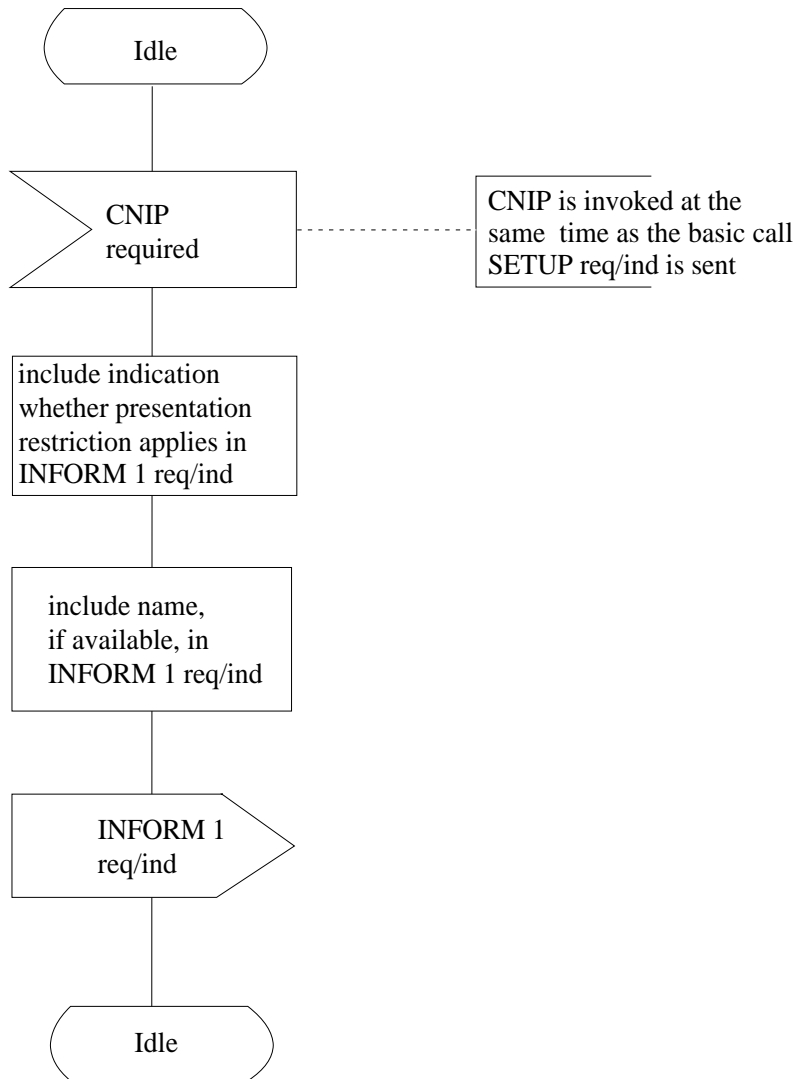

ECMA-84-0057-A

**Figure 6 - SDL for functional entity FE1**

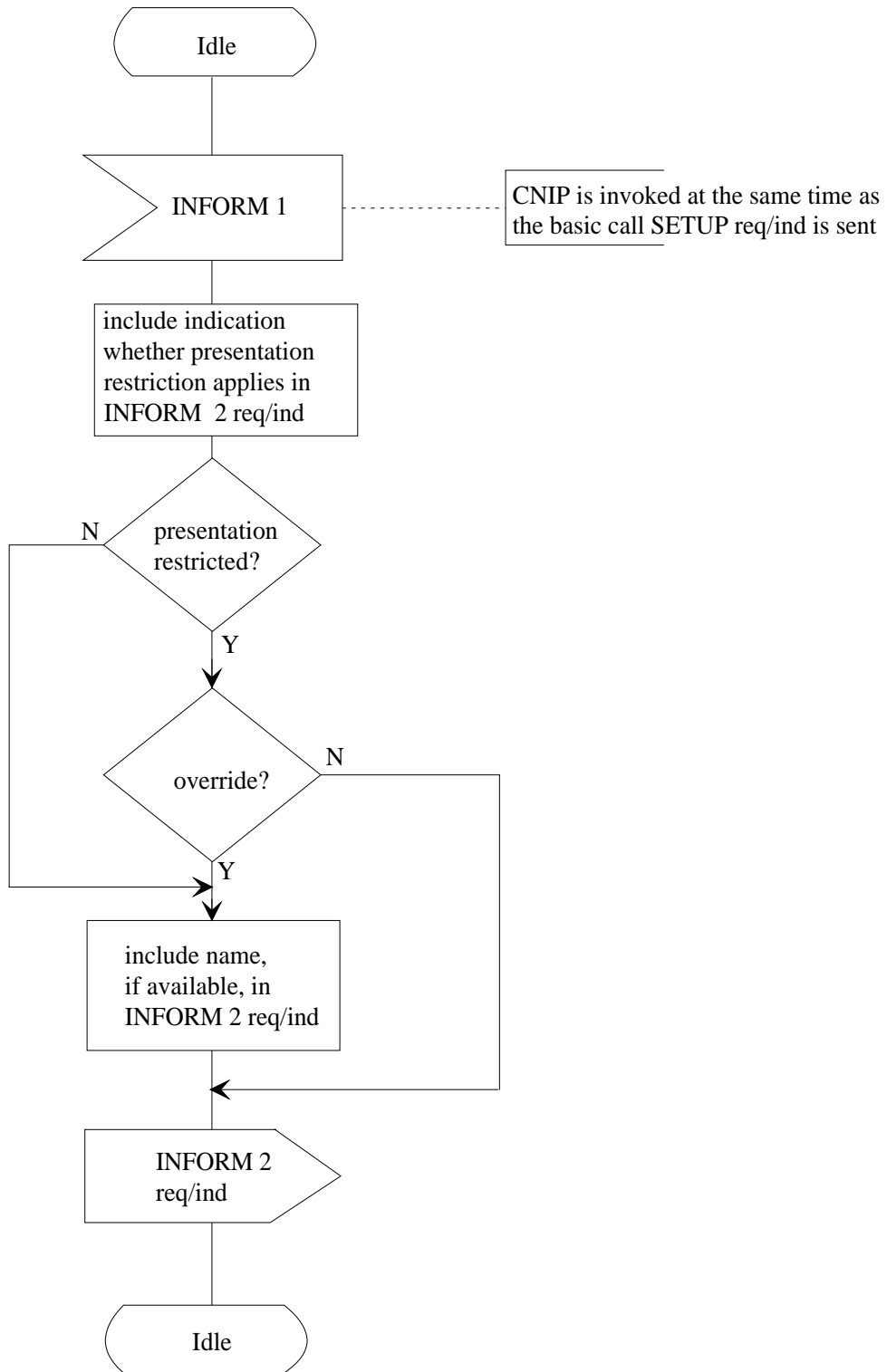

ECMA-94-0058-A

Figure 7 - SDL for functional entity FE2

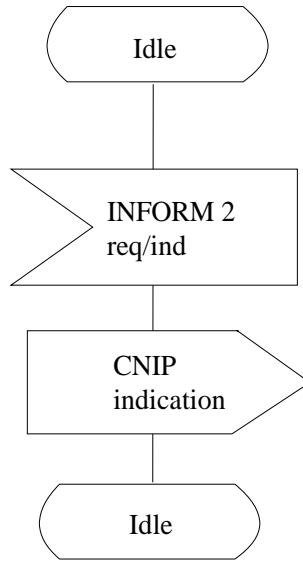

ETMA-94-0059-A

**Figure 8 - SDL for functional entity FE3**

**9.5 Allocation of functional entities to physical locations**

The allocation of FEs to physical equipment for SS-CNIP as shown in table 3 shall apply. If the served user's TE is the stimulus with respect to SS-CNIP, then FE3 shall be allocated in the Destination PTNX.

**Table 3 - Allocation of functional entities to physical location for SS-CNIP**

FE	Calling User		Called User	
	FE1	FE2	FE3	
Scenario 1	Originating PTNX	Destination PTNX	TE	
Scenario 2	Originating PTNX	Gateway PTNX	other network	
Scenario 3	other network	Destination PTNX	TE	

**10 SS-CONP Stage 2 description**

**10.1 Functional model**

**10.1.1 Functional model description**

The functional model for SS-CONP shall comprise the FEs "CONP Provision" (FE4), "CONP Presentation" (FE5) and "CONP Reception" (FE6). A relationship rc shall exist between FE4 and FE5 and a relationship rd shall exist between FE5 and FE6. Figure 9 shows these FEs and relationships.

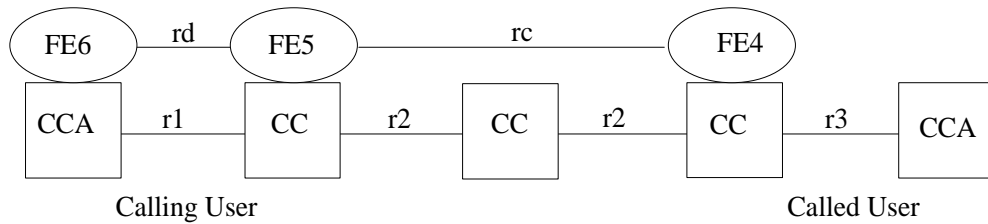

ETSI TS 102 060-A

**Figure 9 - Functional model and relationship to basic call for SS-CONP**

### 10.1.2 Description of functional entities

The functional entities required by SS-CONP shall be as follows:

- FE4 CONP Provision: responsible for provision of the connected/called/busy party name information and associated indicators to FE5.
- FE5 CONP Presentation: responsible for reporting the connected/called/busy party name information and associated indicators to FE6.
- FE6 CONP Reception: responsible for delivery of the connected/called/busy party name information and associated indicators to the PTN user.

*NOTE 7*

*The structure of the name information is described in annex A of this Standard.*

*NOTE 8*

*The possibility that the name information is stored in another FE (data base) and provided to FE4 on request for delivery to FE5 is outside the scope of this Standard.*

*NOTE 9*

*Interactions with certain supplementary services may cause the connected/busy party name to differ from the called party name.*

### 10.1.3 Relationship of functional model to basic call functional model

Figure 9 shows also the relationship with a basic service for SS-CONP.

## 10.2 Information flows

### 10.2.1 Definition of information flows

The information flows INFORM 3, INFORM 4, INFORM 5, INFORM 6, INFORM 7 and INFORM 8 shall apply for SS-CONP.

In the tables below, the column headed "Request" indicates which of the service elements are mandatory (M) and which are optional (O) in a request/indication flow. The column headed "Confirm" indicates which of the service elements are mandatory (M) and which are optional (O) in a response/confirmation information flow.

#### 10.2.1.1 INFORM 3

This unconfirmed information flow, which conveys the connected party name, shall be sent over relationship rc (optional in the case of name unavailable, otherwise mandatory). It shall contain the service elements listed in table 4.

**Table 4 - Content of INFORM 3**

Service elements	Allowed value	Request	Confirm
Presentation Indicator	presentation not restricted presentation restricted connected party name not available	M	
Name		O (NOTE 10)	
Type of Character Set		O (NOTE 10)	
Application Identifier		O	

*NOTE 10*

*The service element shall be present if and only if the name is available.*

**10.2.1.2 INFORM 4**

This unconfirmed information flow, which conveys the connected party name, shall be sent over relationship rd (optional in the case of name not available, otherwise mandatory). It shall contain the service elements listed in table 5.

**Table 5 - Content of INFORM 4**

Service elements	Allowed value	Request	Confirm
Presentation Indicator	presentation not restricted presentation restricted connected party name not available	M	
Name		O (NOTE 11)	
Type of Character Set		O (NOTE 11)	
Application Identifier		O	

*NOTE 11*

*The service element shall be present as indicated if the name is available and not restricted, or if restricted and the calling user has an override service profile. Otherwise the service element shall be omitted.*

**10.2.1.3 INFORM 5**

This unconfirmed information flow, which conveys the called party name, may be sent over relationship rc. It shall contain the service elements listed in table 6.

**Table 6 - Content of INFORM 5**

Service elements	Allowed value	Request	Confirm
Presentation Indicator	presentation not restricted presentation restricted called party name not available	M	
Name		O (NOTE 12)	
Type of Character Set		O (NOTE 12)	
Application Identifier		O	

*NOTE 12*

*The service element shall be present if and only if the name is available.*

**10.2.1.4 INFORM 6**

This unconfirmed information flow, which conveys the called party name, may be sent over relationship rd. It shall contain the service elements listed in table 7.

**Table 7 - Content of INFORM 6**

Service elements	Allowed value	Request	Confirm
Presentation Indicator	presentation not restricted presentation restricted called party name not available	M	
Name		O (NOTE 13)	
Type of Character Set		O (NOTE 13)	
Application Identifier		O	

*NOTE 13*

*The service element shall be present as indicated if the name is available and not restricted, or if restricted and the calling user has an override service profile. Otherwise the service element shall be omitted.*

**10.2.1.5 INFORM 7**

This unconfirmed information flow, which conveys the busy party name, may be sent over relationship rc. It shall contain the service elements listed in table 8.

**Table 8 - Content of INFORM 7**

Service elements	Allowed value	Request	Confirm
Presentation Indicator	presentation not restricted presentation restricted busy party name not available	M	
Name		O (NOTE 14)	
Type of Character Set		O (NOTE 14)	
Application Identifier		O	

*NOTE 14*

*The service element shall be present if and only if the name is available.*

**10.2.1.6 INFORM 8**

This unconfirmed information flow, which conveys the busy party name, may be sent over relationship rd. It shall contain the service elements listed in table 9.

**Table 9 - Content of INFORM 8**

Service elements	Allowed value	Request	Confirm
Presentation Indicator	presentation not restricted presentation restricted busy party name not available	M	
Name		O (NOTE 15)	
Type of Character Set		O (NOTE 15)	
Application Identifier		O	

*NOTE 15*

*The service element shall be present as indicated if the name is available and not restricted, or if restricted and the calling user has an override service profile. Otherwise the service element shall be omitted.*

**10.2.2 Relationship of information flows to basic call information flows**

The SS-CONP information flows INFORM 3 request/indication and INFORM 4 request/indication shall be sent at the same time as the basic call information flow SETUP response/confirmation (r2/r1) for the connected party name. The SS-CONP information flows INFORM 5 request/indication and INFORM 6 request/indication shall be sent at the same time as the basic call information flow REPORT request/indication (r2/r1) for the called party name. The SS-CONP information flows INFORM 7 request/indication and INFORM 8 request/indication shall be sent at the same time as the basic call information flow RELEASE request/indication (r2) and DISCONNECT request/indication (r1) for the busy party name.

**10.2.3 Information flow sequences**

Signalling procedures shall be provided in support of the information flow sequences specified below. In addition, signalling procedures shall be provided to cover other sequences arising from error situations, interactions with basic call, interactions with other supplementary services, different topologies, etc..

In figures 10 and 11 below, SS-CONP information flows are represented by solid arrows and basic call information flows are represented by broken arrows. An ellipse embracing two information flows indicates that the information flows occur together. Within a column representing an SS-CONP functional entity, the numbers refer to functional entity actions listed in 10.3.

Figures 10 and 11 show the information flow sequences for normal operation of SS-CONP.

**10.3 Functional entity actions**

The following FE actions shall occur at the points indicated in figures 10 and 11:

– **FE4 action 401:**

Generate INFORM 3 request/indication (if available) and send it at the same time as the basic call SETUP response/confirmation to the subsequent functional entity FE5. Generate optionally INFORM 5 request/indication (if available) and send it at the same time as the basic call REPORT request/indication to the subsequent functional entity FE5. Generate optionally INFORM 7 request/indication (if available) and send it at the same time as the basic call RELEASE request/indication to the subsequent functional entity FE5.

– **FE5 action 501:**

Receive INFORM 3 request/indication, remove the name according to element Presentation Indicator and the override service profile of the calling user and send this information in INFORM 4 request/indication at the same time as the basic call SETUP response/confirmation to the functional entity FE6. Receive optionally INFORM 5 request/indication, remove the name according to element Presentation Indicator and the override service profile of the calling user and send this information in INFORM 6 request/indication at the same time as the basic call REPORT request/indication to the functional entity FE6. Receive optionally INFORM 7 request/indication, remove the name according to element Presentation Indicator and the override service profile of the calling user and send this information in INFORM 8 request/indication at the same time as the basic call DISCONNECT request/indication to the functional entity FE6.



- **FE6 action 601:**

Receive INFORM 4 request/indication, receive optionally INFORM 6 request/indication and INFORM 8 request/indication and provide the received information to the calling PTN user.

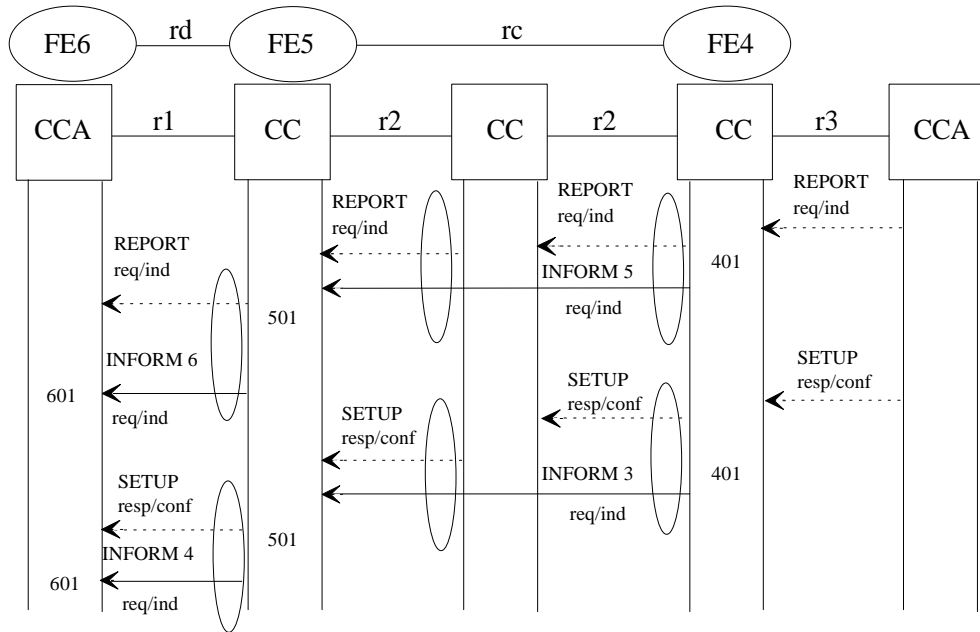

ETMA-94-0061-A

**Figure 10 - Information flow sequence for SS-CONP when the called user is free**

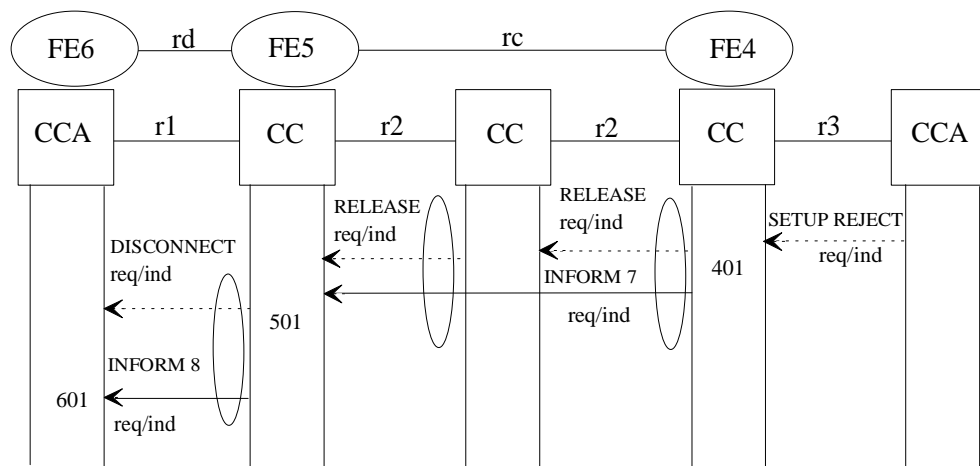

ETMA-94-0062-A

**Figure 11 - Information flow sequence for SS-CONP when the called user is busy**

#### **10.4 Functional entity behaviour**

Figures 12, 13, and 14 are intended to illustrate typical FE behaviour in terms of information flows sent and received. The figures show the behaviour of the functional entities FE4, FE5 and FE6 in providing SS-CONP using the SDL defined in CCITT Rec. Z.100.

Output signals to the left represent information flows to other functional entities or primitives to the calling PTN user. Input signals from the right represent information flows from other functional entities or internal stimuli. The relationship to the basic call process is indicated in the annotations.

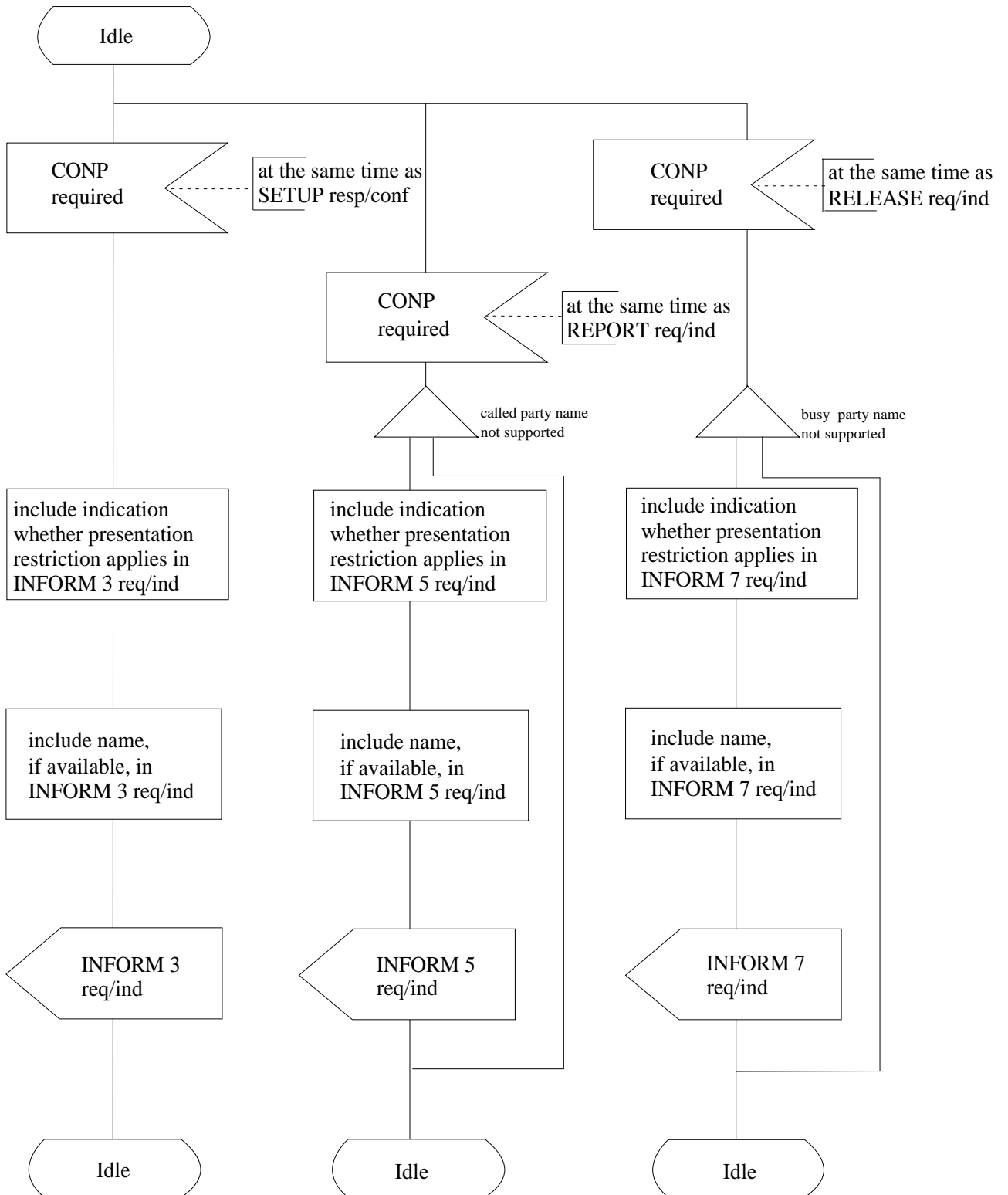

ECMA-94-0063-A

Figure 12 - SDL for functional entity FE4

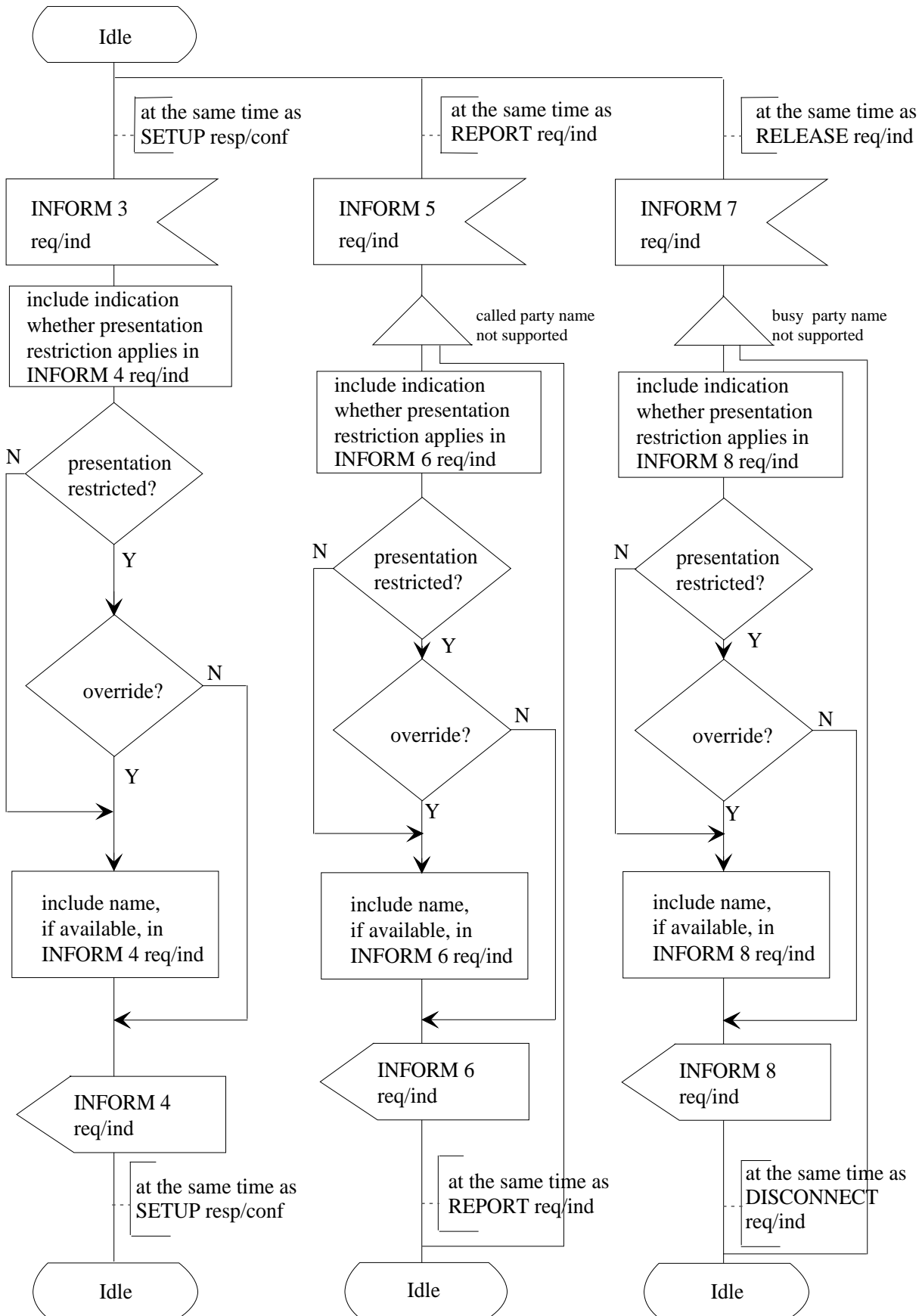
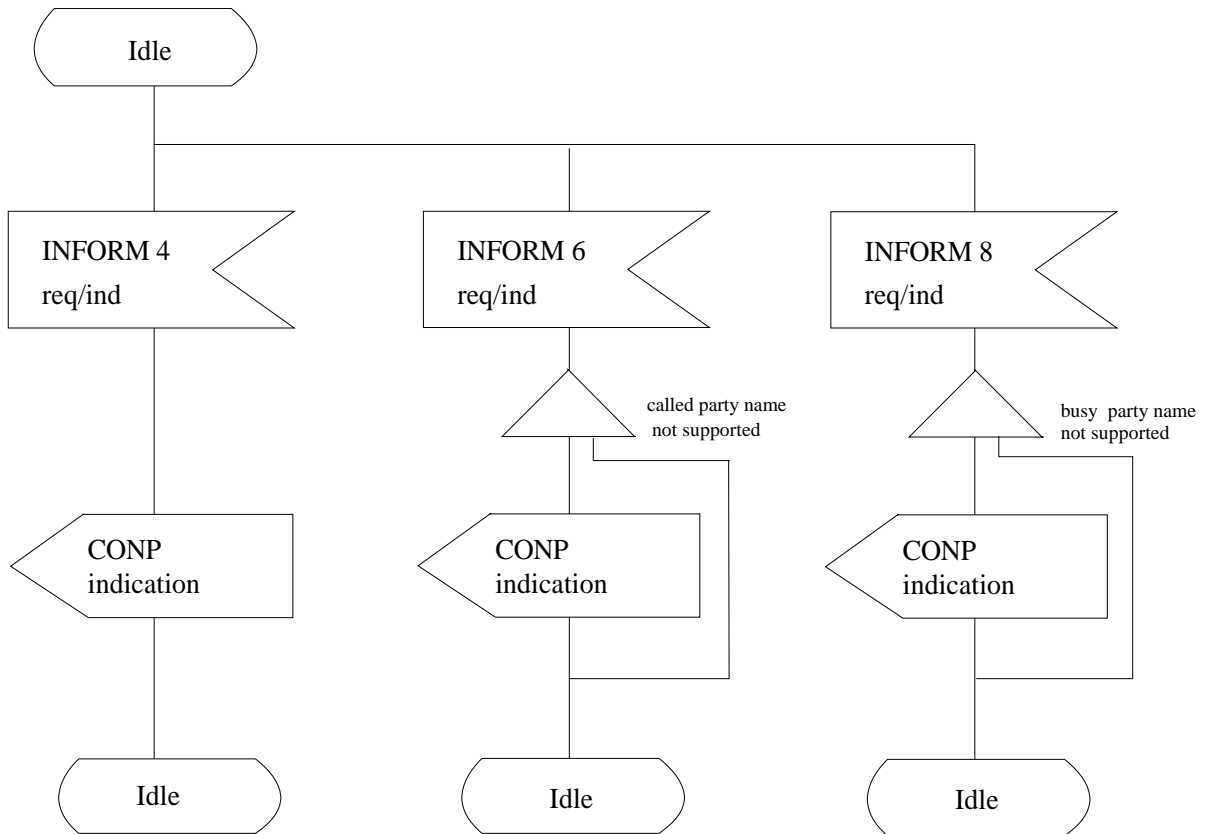

Figure 13 - SDL for functional entity FE5



EE/MA-94-0085-A

Figure 14 - SDL for functional entity FE6

**10.5 Allocation of functional entities to physical locations**

The allocation of FEs to physical equipment for SS-CONP as shown in table 10 shall apply. If the served user's TE is the stimulus with respect to SS-CONP, FE6 shall be located in the Originating PTNX.

Table 10 - Allocation of functional entities to physical location for SS-CONP

FE	Calling User		Called User
	FE6	FE5	FE4
Scenario 1	TE	Originating PTNX	Destination PTNX
Scenario 2	TE	Originating PTNX	other network
Scenario 3	other network	Gateway PTNX	Destination PTNX

**11 SS-CNIR Stage 2 description**

**11.1 Functional model**

**11.1.1 Functional model description**

The functional model for SS-CNIR shall comprise the FEs "Restriction Request" (FE7) and "Restriction Control" (FE8). A relationship shall exist between FE7 and FE8. Figure 15 shows these FEs and relationships.

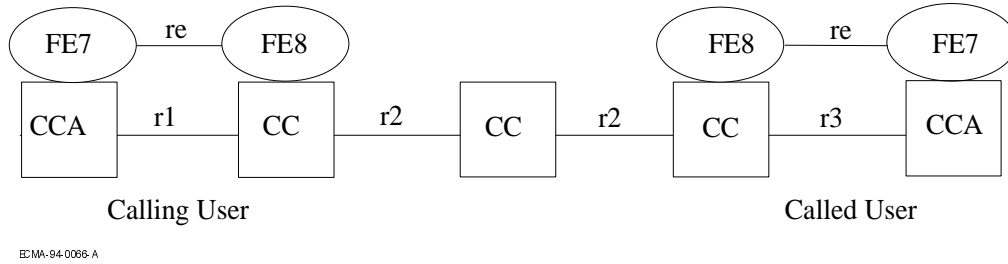

**Figure 15 - Functional model and relationship to basic call for SS-CNIR**

**11.1.2 Description of functional entities**

The functional entities required by SS-CNIR shall be as follows:

- FE7 Restriction Request: responsible for receiving PTN user requests for override of the temporary mode default and passing them on to FE8.
- FE8 Restriction Control: responsible for determining whether to invoke restriction on behalf of a user in a call, based on the user's service profile and any requests from FE7 for the override of the temporary mode default.

**11.1.3 Relationship of functional model to basic call functional model**

Figure 15 shows also the relationship with a basic service for SS-CNIR.

**11.2 Information flows**

**11.2.1 Definition of information flows**

The information flow RESTRICT shall apply for SS-CNIR.

In table 11 below, the column headed "Request" indicates which of the service elements are mandatory (M) and which are optional (O) in a request/indication information flow. The column headed "Confirm" indicates which of the service elements are mandatory (M) and which are optional (O) in a response/confirmation information flow.

This unconfirmed information flow, which conveys a PTN user to override the SS-CNIR temporary mode default, shall be sent over relationship re. It shall contain the service element listed in table 11.

**Table 11 - Content of RESTRICT**

Service elements	Allowed value	Request	Confirm
Restriction Indicator	presentation not restricted presentation restricted	M	

**11.2.2 Relationship of information flows to basic call information flows**

When the calling PTN user wishes to override the SS-CNIR temporary mode default, the Restrict request/indication information flow shall be sent at the same time as the basic call information flow SETUP request/indication (r1/r3).

When the called PTN user wishes to override the SS-CNIR temporary mode default, the Restrict request/indication information flow shall be sent at the same time as the basic call information flow SETUP response/confirmation (r1/r3).

*NOTE 16*

*If FE8 invokes SS-CNIR on behalf of the calling or called user (automatically or on request from the PTN user), an indication that restriction applies is included in the INFORM 1 request/indication, INFORM 3 request/indication, INFORM 5 request/indication or INFORM 7 request/indication information flow respectively. It is then the responsibility of the FEs of SS-CNIP or SS-CONP to ensure that identification information is not presented to the other user.*

### 11.2.3 Information flow sequences

Signalling procedures shall be provided in support of the information flow sequences specified below. In addition, signalling procedures shall be provided to cover other sequences arising from error situations, interactions with basic call interactions with other supplementary services, different topologies, etc..

In figure 16, SS-CNIR information flows are represented by solid arrows and basic call information flows are represented by broken arrows. An ellipse embracing two information flows indicates that the two information flows occur together. Within a column representing a SS-CNIR functional entity, the numbers refer to functional entity actions listed in 11.3.

Figure 16 shows the information flow sequences for normal operation of SS-CNIR.

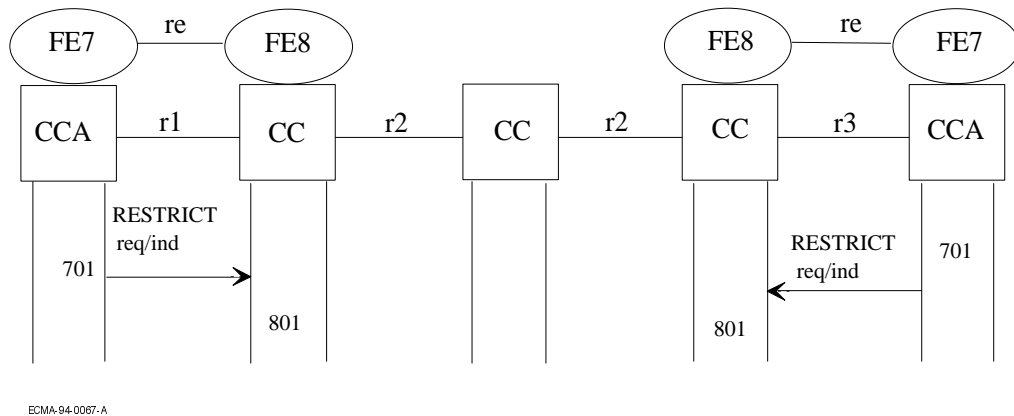

Figure 16 - Information flow sequence for SS-CNIR

### 11.3 Functional entity actions

The following FE actions shall occur at the points indicated in figure 16:

– **FE7 action 701:**

If the served user wishes to override the CNIR temporary mode restriction default, generate a RESTRICT request/indication and send to FE8.

– **FE8 action 801:**

Assign the appropriate presentation restriction indicator to the served user's name identification, based on whether CNIR permanent mode or temporary mode applies and, in the case of temporary mode, whether a request to override the default has been received from FE7.

### 11.4 Functional entity behaviour

Figures 17 and 18 are intended to illustrate typical FE behaviour in terms of information flows sent and received. The figures show the behaviour of the functional entities FE7 and FE8 in providing SS-CNIR using the SDL defined in CCITT Rec. Z.100.

Output signals to the right represent information flows to other functional entities. Input signals from the left represent internal stimuli or input from other functional entities. The relationship to the basic call process is indicated in the annotations.

### 11.5 Allocation of functional entities to physical locations

The allocation of FEs to physical equipment for SS-CNIR as shown in table 12 shall apply. If the served user's TE is stimulus with respect to SS-CNIR, FE7 shall be located in the served user's PTNX.

**Table 12 - Allocation of functional entities to physical location for SS-CNIR**

FE	Calling User		Called User	
	FE7	FE8	FE8	FE7
Scenario 1	TE	Originating PTNX		
Scenario 2			Destination PTNX	TE

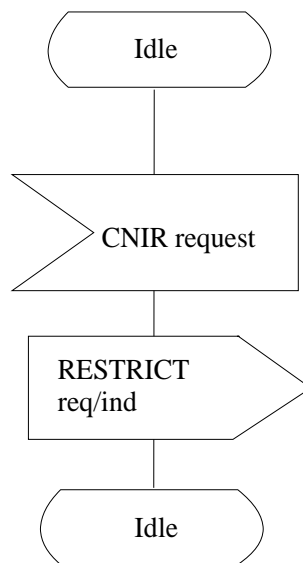

EDMA-94-0088-A

**Figure 17 - SDL for functional entity FE7**



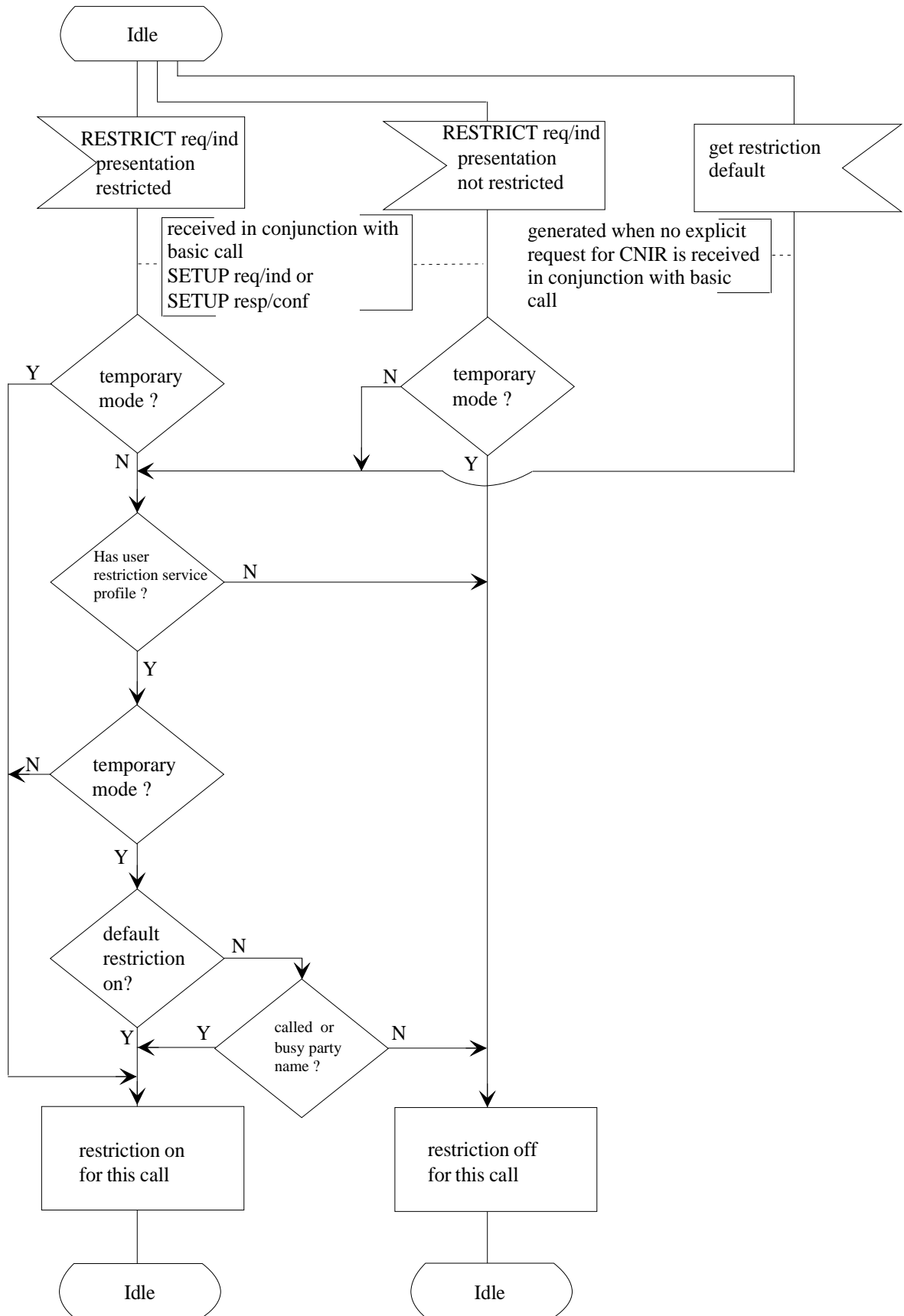

ETMA-04-0089-A

Figure 18 - SDL for functional entity FE8



**Annex A**  
**(normative)**

**Structure and content of a PTN name**

The string of characters, which constitutes a name, shall be accompanied by the indication of the type of character set used and, optionally, by an application identifier.

The application identifier is defined as manufacturer-specific information which can imply the structure of the name information.

Various character sets may be used including an application-specific character set which is qualified by manufacturer-specific information. At least one of the specified standard character sets shall be supported by a manufacturer.

The list of possible character sets shall include:

- the 8-bit single-byte coded character set defined in ISO 8859, Part 1: Latin alphabet no.1.
- the character set defined in CCITT Rec. T.61.

Not all of the specified characters in a set have to be implemented by a PTNX or a TE.

Other character sets may be added to the list of possible character sets in future editions of this ECMA Standard.









**This Second Edition of Standard ECMA-163 is available free of charge from:**

**ECMA  
114 Rue du Rhône  
CH-1204 Geneva  
Switzerland**

**Fax: +41 22 849 60 01  
Internet: [helpdesk@ecma.ch](mailto:helpdesk@ecma.ch)**

**This Standard can also be downloaded as files E163-PSC.EXE and E163-DOC.EXE from ECMANEWS**