

Memento 2025

Table of Contents

Preface	3
Purpose and membership	4
Ecma's role in International Standardization	5
Organization of Ecma International*	6
General Assembly	8
Ordinary members	9
Associate members	10
SME members	11
SPC members	12
Not-for-Profit members	13
Technical Committees	15
Index of Ecma Standards	59
Ecma Standards and corresponding International and European Standards	62
Ecma Standards in force (electronically available here)	63
Technical Reports in force (electronically available here)	78
List of representatives	81
Ecma By-laws	91
Ecma Rules	98
Ecma IPR policies	103
Ecma Code of Conduct in patent matters	104
Ecma Royalty-Free patent policy extension option	106
Ecma text copyright policy	108
Ecma policy on submission, inclusion and licensing of software	110
Ecma trademark matters	112
Withdrawn Ecma Standards and Technical Reports	113
History of Ecma International	121
Ecma Fellow award	122
Past Presidents / Secretaries General	123
About the Ecma Mementos	125
Ecma privacy policy	125

Ecma International® text and logo are registered [trademarks](#) of Ecma International.



Preface

In today's interconnected world, Information and Communication Technology (ICT) and Consumer Electronics (CE) are critical drivers of economic growth and societal development. The seamless exchange of data—encompassing text, images, and audiovisual content—is essential for thriving in global markets. With the rapid digitalization of media, process automation, and the ubiquitous use of devices, ICT, telecommunications, and consumer electronics are becoming increasingly integrated.

Standardization serves as a cornerstone, it ensures interoperability and facilitates data exchange while offering pre-competitive solutions during product development. This process is most effective when it involves all stakeholders from the outset.

Founded in 1961, Ecma International, formerly the European Computer Manufacturers Association (ECMA), has been at the forefront of ICT and CE standardization for over 60 years. As a not-for-profit organization headquartered in Switzerland, Ecma has published 426 standards and 112 technical reports, establishing its role as a pioneer in advancing global standardization.

Standardization is a continuous journey, fuelled by constant innovation and the emergence of new technologies. Ecma's approach ensures it remains ahead of the curve, addressing the urgent need for standardized solutions in evolving technological landscapes. Many Ecma standards have been adopted as the foundation for international and European standards. Since its inception, Ecma has maintained close ties with the International Organization for Standardization (ISO) and the International Electrotechnical Commission (IEC). These collaborations, particularly with ISO/IEC JTC 1, have led to groundbreaking initiatives.

Ecma standards are crafted by expert members from diverse fields, industry, academia, and research; including the Open Source communities. These professionals work collaboratively in consensus-driven environments to develop technical solutions that are implementation-ready and tailored for product development and testing.

The benefits of Ecma membership

- **Early insight into trends:** Members gain access to emerging technological trends and insights into standardization requirements, particularly in pioneering fields.
- **Efficient development process:** Ecma's streamlined processes, small working groups, and active collaboration ensure the rapid creation of standards and reports.
- **Global alignment:** Ecma adheres to World Trade Organization (WTO) principles for standardization, striking a balance between speed and consensus to meet diverse needs.
- **Pathway to global standards:** Ecma standards can serve as final deliverables or be proposed to other Standards Development Organizations (SDOs), for broader adoption.

The active participation of global stakeholders ensures that Ecma standards achieve widespread implementation and acceptance in the worldwide market. This collaboration also reflects Ecma's commitment to fostering interoperability and innovation.

Looking ahead, Ecma is dedicated to playing a key role in the rapid advancements of ICT, telecommunications, and CE. By fostering collaboration and delivering world-class standards, Ecma aims to bridge cutting-edge technologies with standardization needs, ensuring a robust foundation for the future of innovation. In addition, Ecma is addressing critical areas such as artificial intelligence, environmental sustainability, and security, ensuring that Ecma standards not only address the technological advancements of today but also anticipate the challenges and responsibilities of tomorrow.

The President, Geneva, January 2025.

Purpose and membership

The Purpose of Ecma International is:

- To develop, in co-operation with the appropriate national, European and international organizations as a scientific endeavour and in the general interest, standards and technical reports in the fields of information and communications technologies.
- To encourage the correct use of standards by influencing the environment in which they are applied.
- To publish the Ecma Standards and Technical Reports - after their approval by at least two-thirds of all Ordinary Members - free of charge and freely copyable to all interested parties.

The Association consists of Company members (i.e., ordinary, associate, Small and Medium sized Enterprises (SME) and Small Private Companies (SPC) members), and not-for-profit (NFP) members such as universities.

Ordinary membership may be applied for by a company which has interest and experience in matters related to one or more Technical Committees of the Association, which wishes to exert the right to vote at the Technical Committees and at the General Assembly and which wishes to exert other exclusive rights defined in the By-laws and Rules.

All other membership classes have the right to vote on the Technical Committee level only.

Associate membership may be applied for by a company which has interest and experience in matters related to one or more of the Technical Committees of the Association but without the right to vote in the General Assembly.

A company which has similar interests as an associate member and an annual global turnover of less than one hundred million Swiss Francs may be admitted as SME member.

An organization - a company or other legal for-profit organization - which has similar interests as an associate member, an annual global turnover of less than Swiss Francs 10'000'000.- and no more than 25 employees, may be admitted as SPC member.

NFP membership may be applied for by a non-profit-making organization. If an NFP is an organization with several organizations as members, then normally it can only become an NFP member in Ecma if its members do not qualify for Company membership in Ecma.

The Association is a non-profit-making organization and does not devote itself in any commercial activity.

Ecma's role in International Standardization

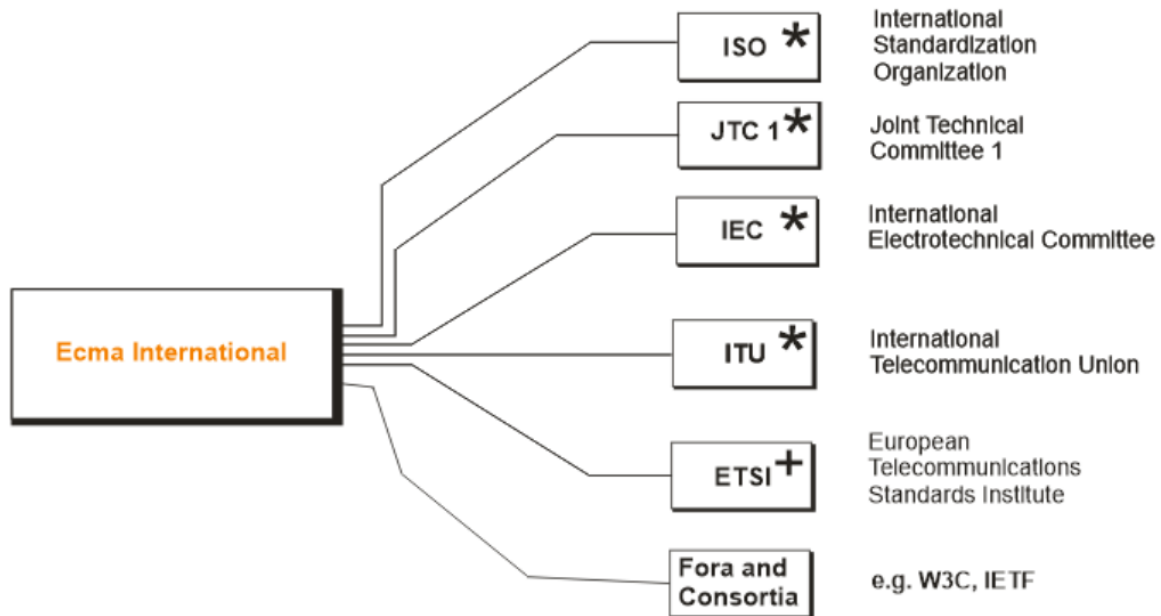

94-0006-C

* SSO – Standard Setting Organization

+ ESO – European Standardization Organization

Ecma International has close working relations - such as liaisons, co-operation agreements, and memberships - with European and international standardization bodies as well as to some Fora and Consortia.

Organization of Ecma International*

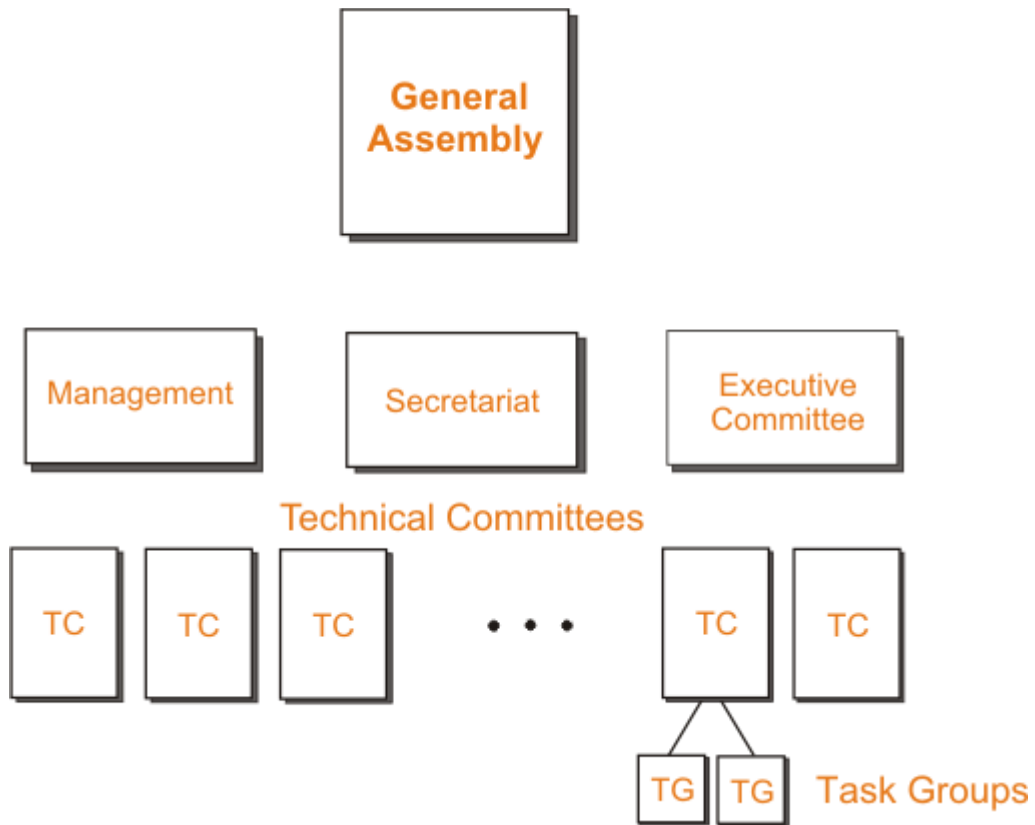

94-0007-C

* Often called Ecma short for Ecma International.

Management

President
Daniel Ehrenberg
(Bloomberg)

Vice-President
Jochen Friedrich
(IBM)

Treasurer
Luoming Zhang
(Huawei)

Secretariat

Secretary General
Samina Husain

Chief Technical Officer
Patrick Lüthi

Office Manager
Isabelle Walch

Secretariat and webmaster
Patrick Charollais

Executive Committee

Chair
Jochen Friedrich (IBM)

Members

From the Ordinary members
Theresa O'Connor (Apple)
Chris Wilson (Google)

From the Non-ordinary members
Mikhail Barash (University of Bergen)
Patrick Dwyer (ServiceNow)
Peter Hoddie (Moddable)
Ross Kirsling (Sony Interactive Entertainment)



General Assembly

Agoric Systems Dean Tribble

Alibaba Yefei Zheng

Apple Theresa O'Connor
alternate: Michael Saboff

Beijing Bytedance Xuan Huang

Bloomberg Daniel Ehrenberg
alternate: Andrew Paprocki

Cloudflare James Snell

Dell Chris E. Peterson

Deno Land Luca Casonato

F5 Networks Michael Ficarra

Functional Software Armin Ronacher

Google Shu-yu Guo
alternate: Chris Wilson

GVE Yu Kusakabe
alternate: Koji Fusa

HEAD acoustics Roland Sottek

HeroDevs Jordan Harband

Hitachi Toshiko Aizono
alternate: Osamu Namikawa

HP Inc. Nathan Moin
alternate: Mercedes Mira Costa

Huawei Luoming Zhang
alternate: Fan Hou

IBM Jochen Friedrich

Igalia Ujjwal Sharma

JetBrains Vladislav Minaev
alternate: Dmitry Makhnev

Lockheed Martin Alan Hohn
alternate: Ian Dunbar-Hall

LytEn Carlos Montalvo

Meta Cami Williams

Microsoft Brian Terlson

Moddable Tech Peter Hoddie

Oracle America Lukas Stadler

Oramasearch Michele Riva

Pax Andromeda Francisco Tolmasky

Record Replay Jason Laster

Salesforce.com Caridy Patino

ServiceNow Priya Gopalan

Shopify Ilya Grigorik

Sony Interactive Entertainment Ross Kirsling

Sujitech Yisi Liu

360 Technology Group Zhijie Li
alternate: Yuan Liangliang

Vercel Dominic Gannaway

Zalari Christian Ulbrich



Ordinary members

Apple
One Apple Park Way
CUPERTINO, CA 95014
USA

Bloomberg
731 Lexington Avenue
NEW YORK, NY 10022
USA

Google Inc.
1600 Amphitheatre Parkway
MOUNTAIN VIEW, CA 94043
USA

Huawei Technologies Co., Ltd
Bantian
Longgang District
SHENZHEN 518129
China

IBM Europe
Avenue de Cortenbergh 116
B-1000 BRUSSELS
Belgium

Meta, Inc.
1 Hacker Way
MENLO PARK, CA 94025
USA

Associate members

Alibaba (China) Co., Ltd
No. 969 Wenyi West Road
Yuhang District
HANGZHOU 311121
China

Beijing Bytedance Network Technology
Building 1
Zhonghang Plaza
No 43 Beisanhuand West Road
Haidian District
BEIJING 100080
China

Cloudflare, Inc.
101 Townsend St
SAN FRANCISCO, CA 94107
USA

Dell Technologies, Inc.
One Dell Way
Mail Stop RR5-17
ROUND ROCK, TX 78682
USA

F5 Networks
801 5th Ave
SEATTLE, WA 98104
USA

Functional Software Inc. (Sentry)
Handelskai 132a/1/46
1020 VIENNA
Austria

Hitachi Ltd
292 Yoshida-cho
Totsuka-ku, Yokohama-shi
KANAGAWA 244-0817
Japan

HP Inc.
1501 Page Mill Road
Building 4
PALO ALTO, CA 94304
USA

JetBrains s.r.o
IntelliJ Department
Kavčí Hory Office Park
Na Hřebenech II 1718/8
PRAHA 4 – Nusle 14000
Czech Republic

Lockheed Martin Corporation
6801 Rockledge Drive
BETHESDA, MD 20817
USA

Microsoft Corporation
One Microsoft Way
REDMOND, WA 98052
USA

Oracle America, Inc.
500 Oracle Parkway
REDWOOD SHORES, CA 94065
USA

Salesforce.com, Inc.
The Landmark @ One Market
Suite 300
SAN FRANCISCO, CA 94105
USA

ServiceNow, Inc.
2225 Lawson Lane
SANTA CLARA, CA 95054
USA

Shopify Inc.
33 New Montgomery St #750
SAN FRANCISCO, CA 94105
USA

Sony Interactive Entertainment LLC
400 2nd Street
SAN FRANCISCO, CA 94107
USA

360 Technology Group Co., Ltd
No. 6 Jiuxianqiao Road
Chaoyang District
BEIJING
China

SME members

HEAD acoustics GMBH
Eberstr. 30a
D-52134 HERZOGENRATH
Germany

HeroDevs
9561 S 700 E #201
SANDY, UT 84070
USA

Igalia, S.L.
Bugallal Marchesi, 22, 1º
15008 A CORUÑA
Galicia
Spain

LytEn, Inc.
933 Kifer Road
SUNNYVALE, CA 94086
USA

Vercel
440 N Barranca Ave #4133
COVINA, CA 91723
USA

SPC members

Agoric Systems
388 Market Street
Suite 920
SAN FRANCISCO, CA 94111
USA

Deno Land Inc.
251 Little Falls Dr
WILMINGTON, DE 19808-1674
USA

GVE Ltd.
2-9-19 Midorigaoka
Meguro-ku
TOKYO 152-0034
Japan

Moddable Tech, Inc.
326 Stanford Avenue
MENLO PARK, CA 94025
USA

Oramasearch, Inc.
347 Lexington Street
SAN FRANCISCO, CA 94110
USA

Pax Andromeda (RunKit, Inc.)
70 Maddox Dr. NE
ATLANTA, GA 30309
USA

Record Replay Inc.
548 Market St
Suite 78081
SAN FRANCISCO, CA 94104
USA

Sujitech, LLC (Mask Network)
46 Songyuan Road
15-201
SHANGHAI, 200336
China

Zalari GmbH
Hermann-Mende-Strasse 4
D-01099 DRESDEN
Germany

Not-for-Profit members

AboutCode Europe ASBL
Avenue Coghen 157
B-1180 UCCLÉ
Belgium

Archive Disc Test Center – NPO Entity
c/o Bifröstec Inc.
Inaoka Kudan Bldg, 6th floor
2-38 Kandajimboh-cho
Chiyoda-ku
TOKYO 101-0051
Japan

Ben Gurion University of the Negev
P.O. Box 653
BEER SHEVA 84105
Israel

Datlas, Inc.
1210 W 7th St
MICHIGAN CITY, IN 46360
USA

Dr. G.R. Damodaran College of Science
Civil Aerodrome Post
COIMBATORE 641014
India

Ecole Polytechnique Fédérale de Lausanne (EPFL)
EPFL/STI/IEL/GR-EB ELD238
Station 11
CH-1015 LAUSANNE
Switzerland

ETH Zürich
ETH Zentrum
Clausiusstr. 59
CH-8092 ZÜRICH
Switzerland

ETRI
161 Gajeong-Dong
Yuseong-gu
DAEJEON 305-700
Republic of Korea

Hosei University
3-7-2, kajinocho
Koganei-shi
TOKYO 184-0002
Japan

Humanitarian Toolbox
P.O. Box 212
MEDINA, WA 98039
USA

Interuniversitair Micro-Electronica Centrum vzw (IMEC)
Kapeldreef 75
B- 3001 LEUVEN
Belgium

Imperial College London
Huxley Building
South Kensington Campus
LONDON, SW7 2RH
United Kingdom

Indiana University
107 S Indiana Ave
BLOOMINGTON, IN 47405
USA

Indian Institute of Technology
Hauz Khas
NEW DELHI 110016
India

Inria
Zirst / 655, avenue de l'Europe
F-38330 MONTBONNOT SAINT-MARTIN
France

IT University of Copenhagen
Glentevej 67
DK-2400 COPENHAGEN NV
Denmark

Japan Broadcasting Corporation (NHK)
1-10-11 Kinuta, Setagaya
TOKYO 157-8510
Japan

Japan Business Machine and Information System Industries
Association (JBMIA)
Lila Hijirizaka
3-4-10 Mita
Minato-ku
TOKYO 108-0073
Japan

Kahu Research
15, Henridge Place
CHRISTCHURCH 8042
New Zealand

Keio University
5322 Endo Fujisawa
KANAGAWA 252-0882
Japan

Korea University
2511 Sejong-ro Jochiwon
SEJONG CITY
Korea

Lawrence Berkeley National Laboratory (LBNL)
1 Cyclotron Road
Mail Stop 90R4000
BERKELEY, CA 94720
USA

Michigan State University
428 S. Shaw Lane
EAST LANSING, MI 48824
USA

Mozilla Foundation
149 New Montgomery St, floor 4
SAN FRANCISCO, CA 94105
USA

OITDA
Optoelectronics Industry and Technology Development
Association
1-20-10 Sekiguchi, Bunkyo-ku
TOKYO, 112-0014
Japan

OpenJS Foundation
548 Market St. PMB 57274
SAN FRANCISCO, CA 94104
USA

Open Source Business Alliance
Pariser Platz 6a
D-10117 BERLIN
Germany

Osaka Metropolitan University
1-1 Gakuen-cho, Naka-ku, Sakai-shi
OSAKA, 599-8531
Japan

Osaka Sangyo University
3-1-1 Nakagaito Daito
OSAKA, 574-8540
Japan

OWASP Foundation
300 Delaware Ave
Ste 210 #384
WILMINGTON, DE 19801
USA

Purdue University
177 S Russell street
WEST LAFAYETTE, IN 47907-2099
USA

Small Fan Workshop Association
Uchi-Kanda 2-8-8
Chuo Building 4F
Chiyoda-ku
TOKYO
Japan

Tama University
2-14-14 Konan
Minato-ku
TOKYO 108-0075
Japan

The Library of Congress
101 Independence Avenue SE
WASHINGTON DC 20540-4010
USA

The University of Electro-Communications
1-5-1 Chofugaoka
CHOFU 182-8585
Japan

University of Bergen
Department of Informatics
Thormøhlensgate 55
NO-5008 BERGEN
Norway

UC Santa Cruz
Baskin School of Engineering
1156 High Street
SANTA CRUZ, CA 95064
USA

University of South Florida
3650 Spectrum Blvd, Suite 160
TAMPA, FL 33612-9446
USA

University of Turku
Vesilinnantie 3
FI-20500 TURKU
Finland

University of Victoria
EOW 448
3800 Finnerty Rd
VICTORIA, B.C. V8P 5C2
Canada

VCCI Council
Azabudai, Minato-ku
TOKYO 106-0041
Japan



Technical Committees

Active Committees

Product safety	TC12
Electromagnetic Compatibility and Electromagnetic Fields (EMC & EMF)	TC20
Acoustics	TC26
Information storage	TC31
Multimedia coding and communications	TC32
Product-related environmental attributes	TC38
ECMAScript®	TC39
Office Open XML formats	TC45
Open XML Paper Specification (OpenXPS®)	TC46
Programming languages	TC49
Close proximity electric induction data transfer	TC50
Access systems and information exchange between systems	TC51
Dart	TC52
ECMAScript® modules for embedded systems	TC53
Software and system transparency	TC54
Web-interoperable server runtimes	TC55
Natural language interaction protocol for communication with Artificial Intelligence (AI) agents	TC56

ECMAScript® and OpenXPS® are registered trademarks of Ecma International.

JavaScript™ is a trademark of Oracle.



Committees having accomplished their tasks

Codes (Coded Character Sets)	TC1
General Programming Languages	TC2
Problem Analysis and Flow Charting	TC3
Optical Character Recognition	TC4
ALGOL	TC5
COBOL	TC6
Magnetic Ink Character Recognition	TC7
FORTRAN	TC8
Data Transmission	TC9
PL/1	TC10
Numerical Control	TC11
Keyboards	TC13
Paper Sizes	TC14
Volume and File Structure	TC15
Rigid Magnetic Disks	TC16
Magnetic Tapes and Tape Cartridges	TC17
I/O Interface	TC18
Flexible Disk Cartridges	TC19
BASIC	TC21
Database	TC22
Open Systems Interconnection	TC23
Communications Protocols	TC24
Data Networks	TC25
Ada	TC27
Ergonomics of Work Stations	TC28
Document Architecture and Interchange	TC29
SCSI Small Computer Systems Interface	TC30
Portable Common Tool Environment (PCTE)	TC33
Office Devices	TC34
User System Interface	TC35
IT Security	TC36
Application Programming Interface for Windows (APIW)	TC37
Object Data Interfaces	TC40
Platform Independent Computing Environment	TC41
Interconnects	TC42
Universal 3D (U3D)	TC43
Holographic Information Storage Systems (HISS)	TC44
Near Field Communications	TC47
High Rate Wireless Communications	TC48



TC12 – Product safety

Scope:

To consider national and international safety regulations to establish appropriate safety standards for information technology equipment so that they are intrinsically safe and safe for operating and maintenance personnel.

Programme of work:

1. To survey existing national and international standards and recommendations concerned with safety requirements.
2. To study the safety requirements associated with power control and distribution and establish recommendations where appropriate.
3. To consider short circuit and overcurrent protection, earthing, voltage exposure limits, mechanical design, etc., and establish recommendations where appropriate.
4. To develop principles and guidance to identify safeguards.
5. To investigate functional safety aspects.
6. TC20 handles EMF, which is a safety subject, because of their electromagnetic expertise.
7. To assume responsibility for the maintenance of Ecma Standards prepared by TC12.
8. To establish and maintain liaison with other standards organizations in order to present Ecma proposals to them and to make comments on their proposals.

Officers:

Chair

Vacant

Secretary

Patrick Lüthi (Ecma International)

Members

Sabine Janning (IBM)

TC20 – Electromagnetic Compatibility and Electromagnetic Fields (EMC and EMF)

Scope:

Electromagnetic Compatibility and Electromagnetic Fields related to ICT and CE equipment.

Programme of work:

1. To survey Electromagnetic Compatibility (EMC) and Electromagnetic Field (EMF) standards of ICT & CE equipment.
2. To establish measurement methods and limits for the electromagnetic emission and immunity of Information Communication Technology (ICT) & Consumer Electronics (CE) equipment.
3. To establish assessment methods and limits for electromagnetic fields from ICT & CE equipment to prevent excessive human exposure.
4. To maintain Ecma Standards and Technical Reports prepared by TC20.
5. To maintain liaison with other standards organizations dealing with EMC and EMF, to comment on their proposals and to present Ecma proposals.

Officers:

Chair

Sabine Janning (IBM)

Vice-Chair

Jafar Keshvari (Huawei)

Secretary

Jean-Luc Detrez (Ecma International)

Members

Michael Callan (Apple)
Masahiro Hoshino (VCCI)
Yoko Inagaki (VCCI)
Frank Kiernan (Apple)
John Maas (IBM)
Akira Oda (VCCI)
Toshiki Shimasaki (VCCI)
S. Thomas (Apple)
Hitoshi Yokota (Hitachi)

TC26 – Acoustics

Scope:

To recommend standards for determining the noise outputs of different categories of individual items of information technology equipment intended for use in defined working environments; standards for determining total noise levels in the said working environments, these standards to include corresponding methods of measurement; preferred methods of predicting total levels if units of known noise output are installed together.

Programme of work:

1. To categorize the acoustical environments in which information technology equipment is required to work.
2. To survey the various recommendations and requirements for the acoustical environments of these areas .
3. To make recommendations for standard methods of measuring and specifying the noise output of equipment, taking into account the work of ISO/TC43.
4. To consider any special requirements that may arise during non-standard operation, e.g. servicing.
5. To consider what information should be supplied by the manufacturer to facilitate optimum installation and to make recommendations.
6. To follow developments affecting acoustical environment in places of work.
7. To assume responsibility for the maintenance of Ecma Standards prepared by TC26.
8. To maintain liaison with other standards organizations in order to present Ecma proposals to them and to make comments on their proposals.

Officers:

Chair

Seth Bard (IBM)

Vice-Chair

Chris E. Peterson (Dell Technologies)

Secretary

Charles Oppenheimer (Ecma International)

Members

James Albritton (Dell)
Eric Baugh (Apple)
Julian Becker (HEAD acoustics)
Wade Bray (HEAD acoustics)
Patricia Davies (Purdue University)
Connor Duke (Apple)
Isao Endou (JBMIA)
Yusuke Hashimoto (JBMIA)
Kyohei Itagaki (JBMIA)
Joseph Keegan (IBM)
Ikuo Kimizuka (Small Fan Workshop Association)
Takeshi Kitamura (JBMIA)
Colin Masterson (IBM)
Gaku Minorikawa (Hosei University)
Toshiaki Nakayama (Small Fan Workshop Association)
Josiah Radcliffe (HP Inc.)
Abdallah Ramini (IBM)
Roland Sotttek (HEAD acoustics)
Jamil Wakil (HP Inc.)
Yanchu Xu (Apple)
Takuya Yamada (JBMIA)
Sean Zimmerman (Microsoft)



TC26-TG1 – Noise and vibration measurement of small air-moving devices

Scope:

- To develop and maintain standard(s) and technical report(s) for the noise and vibration measurement and analysis of small air-moving devices (AMDs) used for cooling information technology and telecommunications equipment (ITTE);
- To investigate noise and vibration issues of small AMDs used in the cooling of ITTE, and to propose recommended technical solutions.

Programme of work:

1. To maintain [ECMA-275](#) (including investigation of ISO counterparts, ISO 10302 Parts 1 and 2).
2. To monitor technological developments and issues of noise and vibration from small AMDs and other related technologies for efficient cooling of ITTE.
3. To develop recommendations, e.g. standards, for small AMD noise and vibration issues.

Officers:

Convenor

Chris E. Peterson (Dell)

Secretary

Charles Oppenheimer (Ecma International)

Members

Seth Bard (IBM)
Eric Baugh (Apple)
Joseph Keegan (IBM)
Ikuo Kimizuka (Small Fan Workshop Association)
Colin Masterson (IBM)
Gaku Minorikawa (Hosei University)
Josiah Radcliffe (HP Inc.)
Abdallah Ramini (IBM)
Jamil Wakil (HP Inc.)
Yanchu Xu (Apple)



TC26-TG2 – Noise measurement of MFDs and related product categories

Scope:

- To develop and maintain standard(s) and technical report(s) for the noise measurement and analysis of multi-function devices (MFDs) and related product categories;
- To investigate noise and vibration issues of multi-function devices (MFDs) and related product categories, and to propose recommended technical solutions.

Programme of work:

1. To maintain Annex C of [ECMA-74](#) (including investigation of ISO counterparts, ISO 7779 and its referred basic standards).
2. To monitor technological developments and issues of noise and vibration from MFDs and related product categories .
3. To develop recommendations, e.g. standards, for noise and vibration issues.

Officers:

Convenor

Ikuo Kimizuka (Small Fan Workshop Association)

Secretary

Charles Oppenheimer (Ecma International)

Members

Kyohei Itagaki (JBMIA)

Takeshi Kitamura (JBMIA)

Josiah Radcliffe (HP Inc.)

Takuya Yamada (JBMIA)



TC26-TG3 – Psychoacoustic standards for IT and CE equipment

Scope:

To develop psychoacoustic standards for IT and CE equipment.

Programme of work:

1. To stay aware of psychoacoustic developments.
2. To develop and improve psychoacoustic metrics for ITT equipment.
3. To create and maintain psychoacoustic standards for ITT equipment.

Officers:

Convenor

Roland Sottek (HEAD acoustics)

Secretary

Charles Oppenheimer (Ecma International)

Members

Seth Bard (IBM)

Julian Becker (HEAD acoustics)

Wade Bray (HEAD acoustics)

Patricia Davies (Purdue University)

Josiah Radcliffe (HP Inc.)

Sean Zimmerman (Microsoft)

TC26-TG4 – Airborne noise measurement of computer equipment and rack equipment

Scope:

To develop and maintain standard(s) and technical report(s) for the measurement and analysis of airborne noise generated by personal computers, workstations, rack-mountable units, and rack-enclosed systems.

Programme of work:

1. To maintain [ECMA-74](#) while monitoring ISO counterparts like ISO 7779 and their referenced basic standards.
2. To monitor ongoing technology developments in personal computers, workstations, rack-mountable units, and rack-enclosed systems.
3. To develop and maintain standards for airborne noise generated by such equipment.

Officers:

Convenor

Colin Masterson (IBM)

Secretary

Charles Oppenheimer (Ecma International)

Members

Seth Bard (IBM)
Eric Baugh (Apple)
Connor Duke (Apple)
Joseph Keegan (IBM)
Chris E. Peterson (Dell)
Jamil Wakil (HP Inc.)
Yanchu Xu (Apple)



TC26-TG5 – Modular acoustic data acquisition systems

Scope:

To develop and maintain standards and technical reports for acoustic instrumentation. Acoustic instrumentation includes but is not limited to data acquisition (DAQ) modules, which record digital acoustic signals, may read information from microphones, along with other capabilities, and are distinct from sound level meters.

Programme of work:

1. To consider data acquisition, microphone, and related sensor technologies.
2. To stay abreast of related standards including but not limited to sound level meters (such as IEC 61672 and IEC 61183), octave-band and fractional-octave-band (such as IEC 61260), and measurement microphones (such as IEC 61094).
3. To maintain liaison with ISO TC 43/SC 1 "Noise".
4. To monitor technological developments in acoustic instrumentation including data acquisition modules.
5. To develop recommendations, e.g. standards on acoustic instrumentation including data acquisition modules.

Officers:

Convenor
Vacant

Secretary
Charles Oppenheimer (Ecma International)

Members

Seth Bard (IBM)
Chris E. Peterson (Dell)

TC31 – Information storage

Scope:

To identify and develop the minimum number of standards necessary for data interchange and/or storage by means of digitally recorded systems, e.g. optical, magnetic and holographic systems (such as disks, cartridges, ...), and standards necessary for determining the life expectancy of such media.

To study existing Ecma and ISO/IEC labelling, volume and file structure standards and, where necessary, initiate and pursue the development of volume and file structure standards.

Programme of work:

1. To develop standards for optical disks and disk cartridges of 60 mm, 80 mm, 90 mm, 120 mm, 130 mm, 300 mm and 356 mm.
2. To develop standards on methods for determining the life expectancy of optical storage media.
3. To assume responsibility for the maintenance of Ecma Standards prepared by TC31.
4. To monitor technological developments in the field of optical disks and disk cartridges.
5. To maintain liaison with other standards organizations in order to present Ecma proposals to them and to make comments to their proposals.

Officers:

Chair

Taku Hoshizawa (Hitachi)

Vice-Chair

Kei Yamashita (Emeritus member)

Secretary

Patrick Lüthi (Ecma International)

Members

Isao Endou (JBMIA)
Shoichiro Hayashi (JBMIA)
Kanami Ikeda (Osaka Metropolitan University)
Mitsuru Irie (Osaka Sangyo University)
Yushi Komachi (OITDA)
Yoshinobu Mitsuhashi (Archive Disc Test Center)
Tetsuhiko Muroi (Japan Broadcasting Corp.)
Toshihiro Sugaya (UEC)
Shoji Taniguchi (OITDA)
Eriko Watanabe (UEC)
Makoto Yoshioka (OITDA)
Luoming Zhang (Huawei)

TC31-TG2 – Holographic information storage

Scope:

To maintain an overall view and strategy for standardization in the field of holographic information storage systems, and to identify and develop Standards, Technical Reports and Guidelines in this field. To monitor and pursue standardization at a global level with regard to ISO/IEC JTC 1 and the international standardization community in general, including but not limited to the AV, IT and computer interfaces community.

Programme of work:

1. To develop standards for media recorded by holographic means.

This includes but is not limited to:

- the recording format;
- the minimum number of parameters, test methods and reference materials necessary to ensure interchangeability of recorded media;
- protective cases, cartridges or coverings with recording or reproduction devices and equipment.

2. To develop standards on methods for determining the life expectancy of holographic storage media.

3. To assume responsibility for the maintenance of Ecma Standards prepared by TC31-TG2.

4. To monitor technological developments in the field of holographic media.

5. To maintain liaison with other standards organizations in order to present Ecma proposals to them and to make comments to their proposals.

Officer:

Convenor

Vacant

Secretary

Patrick Lüthi (Ecma International)

Members

Kanami Ikeda (Osaka Metropolitan University)

Toshihiro Sugaya (UEC)

Eriko Watanabe (UEC)

Kei Yamashita (Emeritus member)

TC31-TG3 – Volume and file structure

Scope:

To facilitate the interchange of information on media by specifying the format on the recorded structures that contain descriptive information about volumes and the files/directories recorded on the media.

Programme of work:

1. To specify volume and file structure standards for media used in interchange.
2. To specify such standards so that they are independent, where possible, of the standards for the underlying medium.
3. To constitute a coherent family of standards where possible.
4. To assume responsibility for the maintenance of Ecma Standards prepared by TC31-TG3.
5. To maintain liaison with other standards organizations (ISO/IEC JTC 1/SC 23 and SC 29, IEC TC100, OSTA) in order to present Ecma proposals to them and to make comments on their proposals.

Officer:

Convenor

Kei Yamashita (Emeritus member)

Secretary

Patrick Lüthi (Ecma International)

Members

Taku Hoshizawa (Hitachi)

Shoji Taniguchi (OITDA)

Makoto Yoshioka (OITDA)



TC32 – Multimedia coding and communications

Scope:

- To prepare and maintain Ecma Standards and Technical Reports required in the field of multimedia coding and communications, including transmission.
- General items addressed by Standards and Technical Reports are architecture, service, protocol, interface, compatibility, management, media coding and applications aspects.
- To monitor, coordinate and pursue standardization as needed with regard to ISO/IEC JTC1 SC 6 and SC 29 and ITU-T SG16.

Programme of work:

1. To maintain Ecma Standards and Technical Reports in the field of:

- Computer Supported Telecommunications Applications (CSTA);
- Architecture, service and protocol aspects of narrowband and broadband Private Integrated Services Networks (PISNs);
- IP-based multimedia communications in a business environment, including interoperability of narrowband and broadband PISNs with IP networks;
- Spatial Audio (S5-Coding).

2. To provide the framework for standardization of Animated JPEG as an optional extension of the JPEG-1 standard1 (ITU-T T.81 | ISO/IEC 10918-1). This includes requirements, architecture, coding of animated JPEG-1 images, file format and examples of software implementations. This extension is planned to be developed under the [Ecma Royalty Free IPR policy](#).

Officers:

Chair

Bernard Hammer (Ecma International)

Vice-Chair

Vacant

Secretary

Patrick Lüthi (Ecma International)

Members

Bob Combs (Microsoft)
Subrat Kar (IIT Delhi)
Ingrid Moerman (IMEC)



TC38 – Product-related environmental attributes

Scope:

To identify and describe the environmental attributes related to ICT (Information and Communication Technology) and CE (Consumer Electronics) products, during their entire life cycle, from conception to end-of-life treatment.

Programme of work:

1. To develop recommendations, e.g. Standards, on environmental attributes and the presentation thereof for ICT and CE products.
2. To monitor the development of environmental standards, regulations, conformity schemes and other requirements related to ICT and CE products.
3. To promote and maintain Ecma Standards covering product-related environmental attributes. To comment on standards and regulations from outside organizations.
4. To establish and maintain close liaison with other organizations and other fora working in the same or similar fields of activity.

Officers:

Chair

Osamu Namikawa (Hitachi)

Vice-Chair

Vacant

Secretaries

Josée Auber (Ecma International), Patrick Lüthi (Ecma International)

Members

Thomas Barillot (Apple)

Kenneth Christensen (University of South Florida)

Bob Combs (Microsoft)

Jim DeBroy (IBM)

Jay Dietrich (IBM)

Thomas Ebert (Apple)

Isao Endou (JBMIA)

Sharif Farag (Microsoft)

Shoichiro Hayashi (JBMIA)

Tim Karg (HP Inc.)

Steven Kuo (Apple)

Nathan Moin (HP Inc.)

Hidetaka Nitta (JBMIA)

Bruce Nordman (LBNL)

Joe Prisco (IBM)

Kei Yamashita (Emeritus member)



TC38-TG1 – Chemical emissions

Scope:

Chemical emissions

Programme of work:

1. To survey existing national and international standards and recommendations.
2. To monitor regulatory developments.
3. To standardize and harmonise methods to determine the chemical emissions.
4. To maintain its published work.
5. To liaise with relevant standards organizations.

Officers:

Convenor

Vacant

Secretaries

Josée Auber (Ecma International), Patrick Lüthi (Ecma International)

Members

Jim DeBroy (IBM)
Thomas Ebert (Apple)
Tim Karg (HP Inc.)
Nathan Moin (HP Inc.)
Osamu Namikawa (Hitachi)
Hidetaka Nitta (JBMIA)



TC38-TG3 – Environmental declarations

Scope:

Environmental declarations

Programme of work:

1. To survey existing national and international standards and recommendations.
2. To monitor regulatory developments.
3. To standardize and harmonise environmental declarations.
4. To maintain its published work.
5. To liaise with relevant standards organizations.

Officers:

Convenor

Vacant

Secretaries

Josée Auber (Ecma International), Patrick Lüthi (Ecma International)

Members

Thomas Ebert (Apple)
Tim Karg (HP Inc.)
Nathan Moin (HP Inc.)
Osamu Namikawa (Hitachi)

TC39 – ECMAScript®

Scope:

Standardization of the general purpose, cross platform, vendor-neutral programming language ECMAScript®. This includes the language syntax, semantics, and libraries and complementary technologies that support the language. This work intends not to use patents or if so then only royalty free patents. To aid in achieving that objective, this TC is using the Royalty-Free Patent Policy which is available [here](#).

Programme of work:

1. To maintain and update the standard for the ECMAScript® programming language.
2. To identify, develop and maintain standards for libraries that extend the capabilities of ECMAScript®.
3. To develop test suites that may be used to verify correct implementation of these standards.
4. To contribute selected standards to ISO/IEC JTC 1.
5. To evaluate and consider proposals for complementary or additional technologies.

Officers:

Chair group

Chris de Almeida (IBM)
Rob Palmer (Bloomberg)
Ujjwal Sharma (Igalia)

Secretaries

Aki Rose Braun (Ecma International), Samina Husain (Ecma International)

Members

Jesse Alama (Igalia)	Joyee Cheung (Igalia)
Ben Allen (Igalia)	Philip Chimento (Igalia)
Martin Alvarez Espinar (Huawei)	Khaidi Chu (Beijing Bytedance Network Technology)
Knut Anders Stokke (University of Bergen)	Romulo Cintra (Igalia)
Eemeli Aro (Mozilla Foundation)	Nebojša Ciric (Google)
Tab Atkins-Bittner (Google)	Dan Clark (Microsoft)
Felipe Balbontin (Google)	Ashley Claymore (Bloomberg)
Leonardo Balter (Salesforce.com)	Gonzalo Cordero (Salesforce.com)
Mikhail Barash (University of Bergen)	Craig Cornelius (Google)
André Bargull (Mozilla Foundation)	Li Cui (360 Technology Group)
Edgar Barragan (Apple)	Jonathan Dallas (Apple)
Zalim Bashorov (JetBrains)	Pierre-Marie Dartus (Salesforce.com)
Guy Bedford (OpenJS Foundation)	Mark Davis (Google)
Nicholas Behrens (Google)	Benjamin de Kosnik (Mozilla Foundation)
Joshua Blaney (Apple)	Ioanna Dimitriou (Igalia)
Arpad Borsos (Functional Software)	Vladan Djerić (Meta)
Andreu Botella (Igalia)	Philipp Dunkel (Bloomberg)
Andrew Branch (Microsoft)	Daniel Ehrenberg (Bloomberg)
Federico Bucci (Apple)	Brendan Eich (Emeritus member)
Ron Buckton (Microsoft)	Staffan Eketorp (Apple)
Sean Burke (Mozilla Foundation)	Damien Engels (Google)
Jory Burson (OpenJS Foundation)	David Enke (Zalari)
Rick Button (Bloomberg)	Erik Ernst (Google)
Mathias Bynens (Google)	Dominic Farolino (Google)
Ted Campbell (Mozilla Foundation)	Rodrigo Fernandez (ServiceNow)
Gus Caplan (Deno Land)	Michael Ficarra (F5 Networks)
Shane Carr (Google)	Cormac Flanagan (UC Santa Cruz)
Luca Casonato (Deno Land)	Luca Forstner (Functional Software)
Tantek Celik (Mozilla Foundation)	Peter Frivaldszky-Mayer (IBM)
Gary Chang (Salesforce.com)	Tooru Fujisawa (Mozilla Foundation)
Daniel Chao (Apple)	Min Gan (360 Technology Group)
Mingyuan Cheng (Sujitech (Mask Network))	Dominic Gannaway (Vercel)

Philippa Gardner (Imperial College)
Ulises Gascón (OpenJS Foundation)
Sareen Gaurav (Microsoft)
Kevin Gibbons (F5 Networks)
Benoit Girard (Meta)
Kai Gong (Beijing Bytedance Network Technology)
Sam Goto (Google)
Ilya Grigorik (Shopify)
Sathya Gunasekaran (Meta)
Shu-Yu Guo (Google)
Jordan Harband (HeroDevs)
Ryuichi Hayashida (Sony Interactive Entertainment)
Dave Herman (Microsoft)
Peter Hoddie (Moddable Tech)
Mathieu Hofman (Agoric Systems)
Mattijs Hoitink (Apple)
Marja Hölttä (Google)
Fan Hou (Huawei)
Xuan Huang (Beijing Bytedance Network Technology)
Xuan Huang (Meta)
Ryan Hunt (Mozilla Foundation)
Marco Ippolito (HeroDevs)
Iain Ireland (Mozilla Foundation)
Manuel Jasso (Salesforce.com)
Simon Kaegi (IBM)
Takuya Kawasaki (Sony Interactive Entertainment)
Riki Khorana (Sony Interactive Entertainment)
Ross Kirsling (Sony Interactive Entertainment)
Adam Klein (Google)
Artem Kobzar (JetBrains)
Tom Kopp (Zalari)
Tobias Koppers (Vercel)
Mariko Kosaka (Google)
Krzysztof Kotowicz (Google)
Kris Kowal (Agoric Systems)
Jonathan Kuperman (Bloomberg)
Jason Laster (Record Replay)
Arnaud Le Hors (IBM)
Zhao Lei (Alibaba (China))
John Lenz (Google)
Zhijie Li (360 Technology Group)
Yi Long Li (Alibaba (China))
Yubei Li (Beijing Bytedance Network Technology)
Yongbiao Li (Huawei)
Yuan Liangliang (360 Technology Group))
Luigi Liquori (Inria)
Guanyu Liu (360 Technology Group)
Yisi Liu (Sujitech (Mask Network))
Dmitry Lomov (Google)
Shumaf Lopvache (JetBrains)
Randy Luecke (Pax Andromeda (Runkit))
Sergio Maffei (Imperial College)
Younies Mahmoud (Google)
Dmitry Makhnev (JetBrains)
Miles Maltbie (Datlas Inc.)
Hubert Boma Manilla (Mozilla)
Sebastian Markbage (Vercel)
Jan Olaf Martin (Google)
Benedikt Meurer (Google)
Tzvetan Mikov (Meta)
Mark S. Miller (Agoric Systems)
Vladislav Minaev (JetBrains)
Daniel Minor (Mozilla Foundation)
Jeff Morrison (Meta)
Stephen Murphy (Apple)
Sam Mussel (Apple)
Thomas Nattestad (Google)
Daniel Nazer (Mozilla Foundation)
Theresa O'Connor (Apple)
Pieter Ouwkerk (Pax Andromeda (Runkit))
Robert Pameley (Bloomberg)
Andrew Paprocki (Bloomberg)
Aakash Patel (Meta)
Caridy Patino (Salesforce.com)
Dave Poole (Apple)
Lizzie Prader (Moddable Tech)
Ukyo Pu (Alibaba (China))
Jatin Ramanathan (Google)
Nicolò Ribaudò (Igalia)
Justin Ridgewell (Google)
Michele Riva (Oramasearch)
Fabio Rocha (Microsoft)
Armin Ronacher (Functional Software)
Daniel Rosenwasser (Microsoft)
Sam Ruby (IBM)
Michael Saboff (Apple)
Jessica Sachs (HeroDevs)
Markus Scherer (Google)
Joe Sepi (IBM)
Shaheer Shabbir (Apple)
Nan Shang (Beijing Bytedance Network Technology)
Natalie Silvanovich (Google)
Amanda Silver (Microsoft)
Aditi Singh (Igalia)
Henri Sivonen (Mozilla Foundation)
Mathias Skallerud Jacobsen (University of Bergen)
Bradford C. Smith (Google)
Jacob Smith (OpenJS Foundation)
Jovonni Smith-Martinez (Agoric Systems)
James Snell (Cloudflare)
Zev Solomon (Sony Interactive Entertainment)
Patrick Soquet (Moddable Tech)
Maciej Stachowiak (Apple)
Lukas Stadler (Oracle)
Yulia Startsev (Mozilla Foundation)
Shawn Steele (Microsoft)
Jan Stola (Oracle)
Surma Surma (Shopify)

Yusuke Suzuki (Apple)
Asumu Takikawa (Igalia)
Frank Tang (Google)
Greg Tatum (Mozilla Foundation)
Brian Terlson (Microsoft)
Bill Ticehurst (Microsoft)
Sam Tobin-Hochstadt (Indiana University)
Francisco Tolmasky (Pax Andromeda (Runkit))
Dean Tribble (Agoric Systems)
Christian Ulbrich (Zalari)
Daniel Veditz (Mozilla Foundation)
Kyle Verrier (Apple)
Shelley Vohr (Microsoft)
Rick Waldron (Salesforce.com)
Victor Wang (Datlas Inc.)
Yaju Wang (Huawei)
Wenlu Wang (Microsoft)

Greg Whitworth (Salesforce.com)
Jason Williams (Bloomberg)
Allen Wirfs-Brock (Emeritus member)
Andreas Woess (Oracle)
Jack Works (Sujitech (Mask Network))
Chengzhong Wu (Bloomberg)
Weicheng Xie (Beijing Bytedance Network Technology)
Jiming Yang (Beijing Bytedance Network Technology)
Valerie Young (Igalia)
Shijiang Yu (Alibaba (China))
George Zahariev (Meta)
Luoming Zhang (Huawei)
He Zhou (Beijing Bytedance Network Technology)
Simon Zünd (Google)

TC39-TG1 – General ECMAScript® language

Scope:

Standardization of the general purpose, cross platform, vendor-neutral programming language ECMAScript® (JavaScript™). This includes the language syntax, semantics, and libraries and complementary technologies that support the language.

TC39 Royalty Free Task Group permits under special conditions technical contributions by 3rd parties (i.e. non-Ecma TC39 members) to the work of this group.

You are kindly invited to fill in your personal information [here](#) if you wish to contribute as a non-member.

Contributors to the Test262 test suite should upload their software modules for the tests via GitHub; the link to upload the contributions to all versions of Test262 ([ECMA TR/104](#) "ECMAScript® Test Suite") is available [here](#).

Programme of work:

1. To maintain and update the standard for the ECMAScript® (JavaScript™) programming language (such as all editions of [ECMA-262](#)).
2. To develop test suites that may be used to verify the correct implementation of these standards (such as [ECMA TR/104](#))
3. To maintain the [ECMA-404](#) (JSON) standard.
4. To maintain and update the standard for the [ECMA-414](#) ECMAScript® Specification Suite.
5. To contribute selected standards to ISO/IEC JTC 1.

Officers:

Convenor group

Chris de Almeida (IBM)
Rob Palmer (Bloomberg)
Ujjwal Sharma (Igalia)

Secretaries

Aki Rose Braun (Ecma International), Samina Husain (Ecma International)

Members

Jesse Alama (Igalia)	Luca Casonato (Deno Land)
Ben Allen (Igalia)	Tantek Celik (Mozilla Foundation)
Martin Alvarez Espinar (Huawei)	Gary Chang (Salesforce.com)
Knut Anders Stokke (University of Bergen)	Daniel Chao (Apple)
Eemeli Aro (Mozilla Foundation)	Mingyuan Cheng (Sujitech (Mask Network))
Tab Atkins-Bittner (Google)	Joyee Cheung (Igalia)
Felipe Balbontin (Google)	Philip Chimento (Igalia)
Leonardo Balter (Salesforce.com)	Khaidi Chu (Beijing Bytedance Network Technology)
Mikhail Barash (University of Bergen)	Romulo Cintra (Igalia)
André Bargull (Mozilla Foundation)	Nebojša Ciric (Google)
Edgar Barragan (Apple)	Dan Clark (Microsoft)
Zalim Bashorov (JetBrains)	Ashley Claymore (Bloomberg)
Guy Bedford (OpenJS Foundation)	Gonzalo Cordero (Salesforce.com)
Nicholas Behrens (Google)	Craig Cornelius (Google)
Joshua Blaney (Apple)	Li Cui (360 Technology Group)
Arpad Borsos (Functional Software)	Jonathan Dallas (Apple)
Andreu Botella (Igalia)	Pierre-Marie Dartus (Salesforce.com)
Andrew Branch (Microsoft)	Mark Davis (Google)
Federico Bucci (Apple)	Benjamin de Kosnik (Mozilla Foundation)
Ron Buckton (Microsoft)	Ioanna Dimitriou (Igalia)
Sean Burke (Mozilla Foundation)	Vladan Djerić (Meta)
Jory Burson (OpenJS Foundation)	Philipp Dunkel (Bloomberg)
Rick Button (Bloomberg)	Daniel Ehrenberg (Bloomberg)
Mathias Bynens (Google)	Brendan Eich (Emeritus member)
Ted Campbell (Mozilla Foundation)	Staffan Eketorp (Apple)
Gus Caplan (Deno Land)	Damien Engels (Google)
Shane Carr (Google)	David Enke (Zalari)

Erik Ernst (Google)
Dominic Farolino (Google)
Rodrigo Fernandez (ServiceNow)
Michael Ficarra (F5 Networks)
Cormac Flanagan (UC Santa Cruz)
Luca Forstner (Functional Software)
Peter Frivalszky-Mayer (IBM)
Tooru Fujisawa (Mozilla Foundation)
Min Gan (360 Technology Group)
Dominic Gannaway (Vercel)
Philippa Gardner (Imperial College)
Ulises Gascón (OpenJS Foundation)
Sareen Gaurav (Microsoft)
Kevin Gibbons (F5 Networks)
Benoit Girard (Meta)
Kai Gong (Beijing Bytedance Network Technology)
Sam Goto (Google)
Ilya Grigorik (Shopify)
Sathya Gunasekaran (Meta)
Shu-Yu Guo (Google)
Jordan Harband (HeroDevs)
Ryuichi Hayashida (Sony Interactive Entertainment)
Dave Herman (Microsoft)
Peter Hoddie (Moddable Tech)
Mathieu Hofman (Agoric Systems)
Mattijs Hoitink (Apple)
Marja Hölttä (Google)
Fan Hou (Huawei)
Xuan Huang (Beijing Bytedance Network Technology)
Xuan Huang (Meta)
Ryan Hunt (Mozilla Foundation)
Marco Ippolito (HeroDevs)
Iain Ireland (Mozilla Foundation)
Manuel Jasso (Salesforce.com)
Simon Kaegi (IBM)
Takuya Kawasaki (Sony Interactive Entertainment)
Riki Khorana (Sony Interactive Entertainment)
Ross Kirsling (Sony Interactive Entertainment)
Adam Klein (Google)
Artem Kobzar (JetBrains)
Tom Kopp (Zalari)
Tobias Koppers (Vercel)
Mariko Kosaka (Google)
Krzysztof Kotowicz (Google)
Kris Kowal (Agoric Systems)
Jonathan Kuperman (Bloomberg)
Jason Laster (Record Replay)
Arnaud Le Hors (IBM)
Zhao Lei (Alibaba (China))
John Lenz (Google)
Zhijie Li (360 Technology Group)
Yi Long Li (Alibaba (China))
Yubei Li (Beijing Bytedance Network Technology)
Yongbiao Li (Huawei)
Yuan Liangliang (360 Technology Group))
Luigi Liquori (Inria)
Guanyu Liu (360 Technology Group)
Yisi Liu (Sujitech (Mask Network))
Dmitry Lomov (Google)
Shumaf Lopvache (JetBrains)
Randy Luecke (Pax Andromeda (Runkit))
Sergio Maffeis (Imperial College)
Younies Mahmoud (Google)
Dmitry Makhnev (JetBrains)
Miles Maltbie (Datlas Inc.)
Hubert Boma Manilla (Mozilla)
Sebastian Markbage (Vercel)
Jan Olaf Martin (Google)
Benedikt Meurer (Google)
Tzvetan Mikov (Meta)
Mark S. Miller (Agoric Systems)
Vladislav Minaev (JetBrains)
Daniel Minor (Mozilla Foundation)
Jeff Morrison (Meta)
Stephen Murphy (Apple)
Sam Mussel (Apple)
Thomas Nattestad (Google)
Daniel Nazer (Mozilla Foundation)
Theresa O'Connor (Apple)
Pieter Ouwerkerk (Pax Andromeda (Runkit))
Robert Pamely (Bloomberg)
Andrew Paprocki (Bloomberg)
Aakash Patel (Meta)
Caridy Patino (Salesforce.com)
Dave Poole (Apple)
Lizzie Prader (Moddable Tech)
Ukyo Pu (Alibaba (China))
Jatin Ramanathan (Google)
Nicolò Ribaudo (Igalia)
Justin Ridgewell (Google)
Michele Riva (Oramasearch)
Fabio Rocha (Microsoft)
Armin Ronacher (Functional Software)
Daniel Rosenwasser (Microsoft)
Sam Ruby (IBM)
Michael Saboff (Apple)
Jessica Sachs (HeroDevs)
Markus Scherer (Google)
Joe Sepi (IBM)
Shaheer Shabbir (Apple)
Nan Shang (Beijing Bytedance Network Technology)
Natalie Silvanovich (Google)
Amanda Silver (Microsoft)
Aditi Singh (Igalia)
Henri Sivonen (Mozilla Foundation)
Mathias Skallerud Jacobsen (University of Bergen)
Bradford C. Smith (Google)
Jacob Smith (OpenJS Foundation)



Jovonni Smith-Martinez (Agoric Systems)
James Snell (Cloudflare)
Zev Solomon (Sony Interactive Entertainment)
Patrick Soquet (Moddable Tech)
Maciej Stachowiak (Apple)
Lukas Stadler (Oracle)
Yulia Startsev (Mozilla Foundation)
Shawn Steele (Microsoft)
Jan Stola (Oracle)
Surma Surma (Shopify)
Yusuke Suzuki (Apple)
Asumu Takikawa (Igalia)
Frank Tang (Google)
Greg Tatum (Mozilla Foundation)
Brian Terlson (Microsoft)
Bill Ticehurst (Microsoft)
Sam Tobin-Hochstadt (Indiana University)
Francisco Tolmasky (Pax Andromeda (Runkit))
Dean Tribble (Agoric Systems)
Christian Ulbrich (Zalari)
Daniel Veditz (Mozilla Foundation)
Kyle Verrier (Apple)

Shelley Vohr (Microsoft)
Rick Waldron (Salesforce.com)
Victor Wang (Datlas Inc.)
Yaju Wang (Huawei)
Wenlu Wang (Microsoft)
Greg Whitworth (Salesforce.com)
Jason Williams (Bloomberg)
Allen Wirfs-Brock (Emeritus member)
Andreas Woess (Oracle)
Jack Works (Sujitech (Mask Network))
Chengzhong Wu (Bloomberg)
Weicheng Xie (Beijing Bytedance Network Technology)
Jiming Yang (Beijing Bytedance Network Technology)
Valerie Young (Igalia)
Shijiang Yu (Alibaba (China))
George Zahariev (Meta)
Luoming Zhang (Huawei)
He Zhou (Beijing Bytedance Network Technology)
Simon Zünd (Google)

TC39-TG2 – ECMAScript® internationalization API specification

Scope:

To assemble Standard [ECMA-402](#), the ECMAScript® Internationalization API Specification. This Standard defines the application programming interface for ECMAScript® objects that support programs that need to adapt to the linguistic and cultural conventions used by different human languages and countries.

Programme of work:

1. To identify, develop, and recommend to TC39 additions and modifications to [ECMA-402](#) that are consistent with the direction of [ECMA-402](#) as described below:
 - a. To provide a common library that promotes best practices for internationalization.
 - b. To standardize internationalization behavior across all ECMAScript® surfaces.
 - c. To ensure that the [ECMA-402](#) specification is correct and robust.
2. To identify, develop, and recommend to TC39 additions and modifications to [ECMA-262](#) that are necessary for promoting best practices for internationalization.
3. To develop polyfills and test suites that may be used to verify correct implementation of [ECMA-402](#).
4. To liaise with TC39 on the status of the Task Group's progress on ongoing proposals and on other recommended modifications to [ECMA-402](#).
5. To liaise with other standards bodies, including the Unicode Consortium, to ensure that [ECMA-402](#) remains consistent with industry standards for i18n.

Officers:

Convenor

Shane Carr (Google)

Secretaries

Aki Rose Braun (Ecma International), Samina Husain (Ecma International)

Members

Jesse Alama (Igalia)
Ben Allen (Igalia)
Eemeli Aro (Mozilla Foundation)
Sean Burke (Mozilla Foundation)
Philip Chimento (Igalia)
Romulo Cintra (Igalia)
Craig Cornelius (Google)
Chris de Almeida (IBM)
Younies Mahmoud (Google)
Daniel Minor (Mozilla Foundation)
Ujjwal Sharma (Igalia)
Henri Sivonen (Mozilla Foundation)
Yusuke Suzuki (Apple)
Frank Tang (Google)
Greg Tatum (Mozilla Foundation)



TC39-TG3 – Security

Scope:

To ensure the ECMAScript® (JavaScript™) security model is effective for the constantly evolving threat landscape of today and tomorrow.

Programme of work:

1. To assess the security impacts of proposals to TC39.
2. To produce documentation on the ECMAScript® security model.
3. To introduce proposals that will help developers create secure programs.
4. To recommend a committee response to privately disclosed security issues.
5. To maintain best practices or recommendations for writing secure programs.
6. To monitor the changing threat landscape for popular embeddings.

Officers:

Convenor Group

Chris de Almeida (IBM)
Jordan Harband (HeroDevs)
Kris Kowal (Agoric Systems)

Secretaries

Aki Rose Braun (Ecma International), Samina Husain (Ecma International)

Members

Jesse Alama (Igalia)
Guy Bedford (OpenJS Foundation)
Shane Carr (Google)
Luca Casonato (Deno Land)
Daniel Ehrenberg (Bloomberg)
Michael Ficarra (F5 Networks)
Ulises Gascón (OpenJS Foundation)
Peter Hoddie (Moddable Tech)
Mathieu Hofman (Agoric Systems)
Marco Ippolito (HeroDevs)
Mark S. Miller (Agoric Systems)
Caridy Patino (Salesforce.com)
Nicolò Ribaudò (Igalia)
Jovonni Smith-Martinez (Agoric Systems)
Daniel Veditz (Mozilla Foundation)

TC39-TG4 – Source map specification

Scope:

To improve and evolve the existing informal source map specification into an Ecma standard. This specification defines a JSON-based format describing a mapping of compiled/optimized code (including CSS and ECMAScript® code) into its original source, including metadata such as the mapping of certain names. The goal is to improve the development/debugging experience of source map usage, including for ECMAScript®.

Programme of work:

1. To complete and correct the existing source map specification, including:
 - To define the source map specification strongly enough that it can be determined whether both producers and consumers are “conformant”, leading to well-defined fixes.
 - To produce a conformance test suite against this stronger definition.
 - To evolve the existing source map specification rather than creating a new system (e.g., based on DWARF).
2. On that basis, to improve source map expressiveness in various ways, including:
 - To create additional source map capabilities for improving the mapping of names, including function, variable, and property mappings.
 - To improve the association of a source map to the code it refers to, with various possible mechanisms.

Officers:

Convenor Group

Jonathan Kuperman (Bloomberg)
Nicolò Ribaudò (Igalia)

Secretaries

Aki Rose Braun (Ecma International), Samina Husain (Ecma International)

Members

Zalim Bashorov (JetBrains)
Arpad Borsos (Functional Software)
Andreu Botella (Igalia)
Ron Buckton (Microsoft)
Artem Kobzar (JetBrains)
Tobias Koppers (Vercel)
Jason Laster (Record Replay)
Shumaf Lopvache (JetBrains)
Hubert Boma Manilla (Mozilla)
Jan Olaf Martin (Google)
Benedikt Meurer (Google)
Justin Ridgewell (Google)
Armin Ronacher (Functional Software)
Asumu Takikawa (Igalia)
Simon Zünd (Google)

TC39-TG5 – Experiments in programming language standardization

Scope:

To provide a forum for the discussion, development and dissemination of research work on the standardization of ECMAScript® (the JavaScript™ programming language) and related technologies.

Programme of work:

1. To summarize and present ongoing research work from the academic community on JavaScript™ and adjacent technologies
2. To investigate and discuss state-of-the-art approaches to aid the development of TC39 proposals (drawing from areas such as: formalisms, programming language theory, human computer interaction, social science).
3. To produce documentation on best practices from research work to ECMAScript® standardization.
4. To produce and present tools and technologies to aid in the understanding and design of standards for ECMAScript® and adjacent technologies.
5. To continue and broaden the work, in addition to ECMAScript®, with a general investigation of programming languages standardization.
6. To establish and maintain liaison with other Ecma TCs and other standardization bodies as appropriate to facilitate and promulgate the work of the TG, including dissemination in academic and industrial publishing venues.

Officers:

Convenor Group

Mikhail Barash (University of Bergen)
Yulia Startsev (Mozilla)

Secretaries

Aki Rose Braun (Ecma International), Samina Husain (Ecma International)

Members

Jesse Alama (Igalia)
Chris de Almeida (IBM)
Michael Ficarra (F5 Networks)
Nicolò Ribaudò (Igalia)
Jack Works (Sujitech (Mask Network))

TC45 – Office Open XML formats

Scope:

The initial goal of the Technical Committee was to produce a formal standard for office productivity applications within the Ecma International standards process, which is fully compatible with the Office Open XML Formats. The aim was to enable the implementation of the Office Open XML Formats by a wide set of tools and platforms in order to foster interoperability across office productivity applications and with line-of-business systems. Now that ISO/IEC JTC 1/SC 34/WG 4 has taken over the management of the Office Open XML work, the Technical Committee is responsible for assisting WG 4 with the ongoing maintenance and evolution of the standard.

Programme of work:

1. To produce a formal Standard for office productivity documents which is fully compatible with the Office Open XML Formats.

This includes:

a) Produce a standard which is fully compatible with the Office Open XML Formats, including full and comprehensive documentation of those formats in the style of an international standard, with particular attention given to enabling the implementation of the Office Open XML Formats by a wide set of tools and platforms in order to foster interoperability across office productivity applications and with line-of-business systems.

b) Produce a comprehensive set of W3C XML Schemas for the Office Open XML Formats, with particular attention given to self documentation of the schemas and testing of the XSDs for validation using a wide variety of XSD tools of the market and cross platform.

2. To contribute the Ecma Office Open XML Formats standards to ISO/IEC JTC 1 for approval and adoption by ISO and IEC.

Upon completion of the previous items, the role of the Technical Committee will be:

- To assume responsibility for maintaining the Ecma Office Open XML standard.
- To evaluate and consider proposals for complementary or additional technology.
- To assume responsibility for the evolution of the Ecma standard while ensuring backward compatibility with the previous versions to guarantee continuity in the use of the current and future formats.
- To establish and maintain liaison with other Ecma TCs and with other Standards Development Organizations (SDOs) as appropriate to facilitate and promulgate the work of the TC.

Officers:

Chair

John Haug (Microsoft)

Vice-Chair

Vacant

Secretary

Patrick Lüthi (Ecma International)

Members

Tristan Davis (Microsoft)

Alfred Hellstern (Microsoft)

Steven Morris (Library of Congress)

John Roque (Apple)

Shawn Villaron (Microsoft)

TC46 – Open XML Paper Specification (OpenXPS®)

Scope:

The goal of the Technical Committee is to produce a formal standard for an XML-based electronic paper format and XML-based page description language which is consistent with existing implementations of the format called the Open XML Paper Specification (OpenXPS®). The Technical Committee will use the format called the Open XML Paper Specification (OpenXPS®) as a starting point with the aim to provide a standard, secure, and highly trustworthy format that enables a wide set of applications, devices, tools and platforms to implement compatible paginated-document workflows. An additional goal will be to enable the interoperability of independently created software and hardware systems that produce, consume or otherwise process XPS content. The Technical Committee will be responsible for the ongoing maintenance and evolution of the standard.

Programme of work:

1. Produce a formal standard for an XML-based electronic paper format and XML-based page description language which is consistent with existing implementations of the format called the Open XML Paper Specification, including:
 - Produce a fully documented and unambiguous standard for an XML-based electronic paper format and page description language.
 - Produce appropriate W3C XML Schemas to enable automatic verification of files written to the standard.
 - Enable interoperability between existing industry implementations of applications, devices, tools and platforms.
2. Assume responsibility for the ongoing maintenance and evolution of this Ecma International standard.
3. Support backwards compatibility with implementations targeted to prior versions of the standard.
4. Evaluate and consider proposal for complementary or related additional technologies.
5. Establish and maintain liaison with other Ecma TCs and with other Standards Setting Organizations (SSOs) as appropriate to facilitate and promulgate the work of the TC.
6. Evaluate and consider contributing the Ecma standard to an ISO and/or IEC TC for approval and adoption.

Officers:

Chair

Vacant

Vice-Chair

Vacant

Secretary

Patrick Lüthi (Ecma International)

Members

Rex Jaeschke (Microsoft)



TC49 – Programming languages

Scope:

To standardize:

- the programming language C# (C "sharp");
- the programming language Eiffel;
- a Common Language Infrastructure (CLI);
- a CLI binding for C++;
- additional programming languages with cross-language bindings;
- additional vendor-neutral, cross-language programming platforms.

Programme of work:

1. To develop a standard for the programming language C# (pronounced C "sharp").
2. To develop a standard for the Common Language Infrastructure (CLI).
3. To develop a standard for the programming language Eiffel.
4. To develop a standard set of language extensions to provide a CLI binding for C++.
5. To contribute the standards to ISO/IEC JTC 1.
6. To investigate the further direction of standards developed by TC49.
7. To evaluate and consider proposals for complementary or additional technology.
8. To maintain liaison with appropriate other Ecma TCs and TGs and with ISO/IEC JTC 1/SC 22.

Officers:

Chair ad interim

Rex Jaeschke (Microsoft)

Vice-Chair

Vacant

Secretaries

Rex Jaeschke (Microsoft), Patrick Lüthi (Ecma International)

Members

Eric Bezault (ETH)
Karine Bezault (ETH)
Brandon Bray (Microsoft)
Neal Gafter (Meta)
Andy Gocke (Microsoft)
Anders Hejlsberg (Microsoft)
Bertrand Meyer (ETH)
Nigel Perry (Kahu Research)
Peter Sestoft (IT University of Copenhagen)
Jon Skeet (Google)
Mads Torgersen (Microsoft)
Bill Wagner (Humanitarian Toolbox)



TC49-TG2 – C#

Scope:

To standardize the syntax and semantics of a modern, component-based, general purpose, object oriented, and type-safe programming language called C# (pronounced C sharp).

Programme of work:

1. Develop C# language standards.
2. Upon completion of item 1, to investigate the future direction of C# standards, and to evaluate and consider proposals for complementary or additional technology.
3. To establish and maintain liaison with other Ecma TCs and with other Standards Development Organizations (SDOs) as appropriate to facilitate and promulgate the work of the TG.

Officers:

Convenor

Jon Skeet (Google)

Secretaries

Rex Jaeschke (Microsoft), Patrick Lüthi (Ecma International)

Members

Brandon Bray (Microsoft)

Neal Gafter (Meta)

Andy Gocke (Microsoft)

Anders Hejlsberg (Microsoft)

Nigel Perry (Kahu Research)

Peter Sestoft (IT University of Copenhagen)

Mads Torgersen (Microsoft)

Bill Wagner (Humanitarian Toolbox)

TC49-TG3 – Common Language Infrastructure

Scope:

To standardize a common language infrastructure (CLI) to support C#, ECMAScript® and other modern languages.

Programme of work:

1. Develop CLI standards including:

- A common type system used across all supported programming languages;
- Execution Engine Architecture;
- A system architecture and type system;
- Metadata syntax and semantic;
- File format including validation rules;
- Program verification rules that ensure type safety;
- A common intermediate language format for code download and execution, along with metadata that describes the requirements and capabilities of the code;
- A small set of base classes that provide language support and basic application portability.

2. Upon completion of item 1, to investigate the future direction of CLI standards, and to evaluate and consider proposals for complementary or additional technology.

3. To establish and maintain liaison with other Ecma TCs and with other Standards Development Organizations (SDOs) as appropriate to facilitate and promulgate the work of the TG.

Officers:

Convenor

Vacant

Secretary

Patrick Lüthi (Ecma International)

Members

Brandon Bray (Microsoft)

Anders Hejlsberg (Microsoft)

Bertrand Meyer (ETH)

Nigel Perry (Kahu Research)

Peter Sestoft (IT University of Copenhagen)



TC49-TG4 – Eiffel language

Scope:

To standardize the syntax and semantics of a modern, component-based, general purpose, object oriented, and type-safe programming language called Eiffel.

Programme of work:

1. Develop Eiffel language standards.
2. Upon completion of item 1, to investigate the future direction of Eiffel language standards, and to evaluate and consider proposals for complementary or additional technology.
3. To establish and maintain liaison with other Ecma TCs and with other Standards Development Organizations (SDOs) as appropriate to facilitate and promulgate the work of the TG.

Officers:

Convenor

Bertrand Meyer (ETH)

Secretary

Patrick Lüthi (Ecma International)

Members

Eric Bezault (ETH)

Karine Bezault (ETH)

Bertrand Meyer (ETH)



TC50 – Close proximity electric induction data transfer

Scope:

TC50 addresses the need of transferring large multimedia files quickly and easily by using close proximity electric induction .

High-speed close proximity wireless communications using longitudinal electric induction coupling .

Programme of work:

1. To develop and maintain Standards and Technical Reports for the wireless data interface between devices, including physical and link layers using the unique properties of the electric induction coupling principle. Basic technology will be optimized for one-to-one, point-to-point topology for close proximity bi-directional data transfer between two active devices.
2. To cooperate and liaise with other organizations and standardization bodies.
3. To act as the registration authority for the Specifier ID Register.

Officers:

Chair

Vacant

Secretary

Patrick Lüthi (Ecma International)

Members

André Bourdoux (IMEC)

TC51 – Access systems and information exchange between systems

Scope:

- Access System specifies a common language, architecture, interfaces and protocols for the interoperability between different (distributed) sub-systems for access to assets.
- Such assets may be physical such as buildings, transport means, care centres, computers or digitised assets and services e.g. health care.
- The Access System specification describes a framework for existing and new systems that provide access to specific assets.
- Development of standards that enable close proximity communications such as, but not limited to, Near Field Communication Systems (NFC).

Programme of work:

1. To develop and maintain Standards and Technical Reports for interoperability between different sub-systems for access systems.
2. To monitor related standardization activities to avoid duplication, to promote synergies and to promote complementary efforts via internal and external liaisons with - and contribute to - the work of international SDOs.

Officers:

Chair

Masakazu Ito (Hitachi)

Vice-Chair

Kei Yamashita (Emeritus member)

Secretary

Patrick Lüthi (Ecma International)

Members

Touradj Ebrahimi (EPFL)
Shunan Fan (Huawei)
Koji Fusa (GVE Ltd)
Hyun-Kook Kahng (Korea University)
Masahito Kawamori (Keio University)
Jaeyoung Kim (Korea University)
Susumu Kusakabe (GVE Ltd)
Yu Kusakabe (GVE Ltd)
Hiroki Okatani (Japan Broadcasting Corp.)
Keita Takamatsu (GVE Ltd)
Koichiro Tokuoka (Tama University)
Alvin Wang (Huawei)
Nana Yamada (Japan Broadcasting Corp.)
Luoming Zhang (Huawei)
Yanpeng Zhang (Huawei)



TC51-TG1 – Near Field Communications

Scope:

To develop Standards and Technical Reports for Near Field Communication (NFC) Systems, for the realization of simple wireless communication between close coupled devices for network products and consumer equipment.

Programme of work:

1. To develop and maintain Standards and Technical Reports for Near Field Communication.
2. To cooperate and liaise with other organizations and standardization bodies, where appropriate, in particular with ISO/IEC JTC 1, to achieve and promote a unique worldwide set of standards in the area of Near Field Communication Systems.
3. To monitor NFC technology developments and to promote and support its use in suitable application areas.

Officers:

Convenor

Vacant

Secretary

Patrick Lüthi (Ecma International)

Members

Shunan Fan (Huawei)

Masakazu Ito (Hitachi)

Hyun-Kook Kahng (Korea University)

Jaeyoung Kim (Korea University)

Susumu Kusakabe (GVE Ltd)

Kei Yamashita (Emeritus member)

Luoming Zhang (Huawei)

Yanpeng Zhang (Huawei)



TC52 – Dart

Scope:

To standardize the syntax and semantics of a modern, object oriented programming language called Dart as well as standardizing core libraries and **complementary** technologies that support the language. This work intends not to use patents or if so then only royalty free patents. To aid in achieving that objective, this TC is using the Royalty-Free Patent Policy which is available [here](#).

You are kindly invited to register [here](#) if you wish to contribute as a non-member.

Programme of work:

1. To develop Dart language standards and standards for libraries that extend the capabilities of Dart.
2. Upon completion of item 1, to investigate the future direction of Dart language standards, and to evaluate and consider proposals for complementary or additional technology.
3. To develop test suites that may be used to verify the correct implementation of these standards.
4. To establish and maintain liaison with other Ecma TCs and with other Standards Development Organisations (SDOs) and other [groups](#) as appropriate to facilitate and promulgate the work of the TC.

Officers:

Chair

Michael Thomsen (Google)

Vice-Chair

Vacant

Secretary

Samina Husain (Ecma International)

Members

Erik Ernst (Google)

Lasse Reichstein Holst Nielsen (Google)

TC53 – ECMAScript® modules for embedded systems

Scope:

TC53 is bringing the benefits of standard software APIs to embedded systems so creators of hardware products can benefit from the same rapid development and scalability long enjoyed by web developers. To achieve that, TC53 is focusing its efforts on ECMAScript®, the programming language of the web. With over twenty years of use at global scale, ECMAScript® has proven able to adapt to industry trends while delivering stable, compatible development across computers, servers, and mobile devices. Use of the ECMAScript® programming language is now expanding beyond the web into embedded systems powered by resource-constrained devices including microcontrollers and single-board computers.

Today, the diverse hardware used in embedded systems is powered by a mix of software solutions that are incompatible with one another due to differences in silicon design, instruction set architecture, operating system, and software APIs. However, most of these systems are capable of running modern, first-class implementations of the ECMAScript® programming language thereby enabling interoperable development that spans consumer and industrial IoT. Standard APIs become desirable once a common programming language is in place to allow the same task to be performed in the same way across a range of hardware. TC53 is defining these standard APIs for areas that include input/output, sensors, networking, communication, energy management, and displays. These APIs are organized into ECMAScript® modules, rather than an operating system, to allow systems to be constructed using only the modules required by the product.

TC53 is designing APIs for efficient execution in these embedded systems, taking into account code size, memory use, performance, and energy efficiency. In addition, modules are designed for secure operation to ensure the products operate reliably and user privacy is maintained. TC53 is also studying ways to evolve the ECMAScript® language to benefit embedded systems, for example with increased security and runtime efficiency, and is working with TC39 (the ECMAScript® language TC) to incorporate these ideas into the language.

TC53 intends for implementations of its standards to be deployed without royalty payments. Consequently, the committee does not intend to incorporate work subject to a patent unless it is available royalty free. To aid in achieving that objective, TC53 operates under the Royalty-Free Patent Policy which is available [here](#).

Programme of work:

1. To define requirements for the needed interfaces and protocols based on identified product needs.
2. To establish communication with user communities and other standardization bodies to harmonize and ensure interoperability (e. g. JTC 1/SC 41, IEC TC124, ITU-T SG20, W3C, etc.).
3. To continue to develop relevant pre-standardization material and proofs of concept.
4. To study the impact on privacy and data security.
5. To launch specific TGs as the need arises.
6. Standardization activities that would lead to an ECMAScript®-based platform for embedded systems and extensions to ECMAScript®.
7. To study existing standardization work on the definition of formats of sensor data for general data interchange.

Officers:

Chair

Peter Hoddie (Moddable Tech)

Vice-Chair

Vacant

Secretary

Patrick Lüthi (Ecma International)

Members

David Ackley (Michigan State University)

Andrea Basso (University of Victoria)

Elisa Bertino (Purdue University)

Andy Carle (Moddable Tech)

Michael FIG (Agoric Systems)

Hyun-Kook Kahng (Korea University)

Josué Kpodo (Michigan State University)

Mark S. Miller (Agoric Systems)

Carlos Montalvo (LytEn Inc.)

Lizzie Prader (Moddable Tech)

Josh Siegel (Michigan State University)

Patrick Soquet (Moddable Tech)

Rick Waldron (Salesforce.com)

Kei Yamashita (Emeritus member)

TC54 – Software and system transparency

Scope:

Software transparency refers to the practice of providing comprehensive and easily accessible information about the components and dependencies within a piece of software, how the software was manufactured, and the behaviours observed or attestations made by the organization that developed the software.

This transparency aims to enhance security, compliance, and overall understanding of supply chain risk. A critical tool in achieving software transparency is a Bill of Materials (BOM), a structured list detailing all software components used in an application. Through software transparency, organizations can better manage software vulnerabilities, track open-source components, and foster a more secure and accountable software development and distribution ecosystem. TC54 aims to standardize core data formats, APIs and algorithms around software transparency information. This work intends not to use patents or if so then only royalty free patents. To aid in achieving that objective, this TC is using the Royalty-Free Patent Policy which is available [here](#).

Programme of work:

1. To develop a standard for the CycloneDX software transparency and Bill of Materials specification.
2. To develop a standard for the Transparency Exchange API (Project Koala) for discovering and sharing of software transparency information.
3. To develop a standard and guidance for multiple BOM merging algorithms.
4. To investigate the further direction of standards in the software transparency space.
5. To evaluate and consider proposals for complementary or additional technology.

Officers:

Chair

Steve Springett (ServiceNow)

Vice-Chair

Alyssa Wright (Bloomberg)

Secretary

Samina Husain (Ecma International)

Members

Vinod Anandan (OWASP)
Chris de Almeida (IBM)
Ian Dunbar-Hall (Lockheed Martin)
Patrick Dwyer (ServiceNow)
Daniel Ehrenberg (Bloomberg)
Lars Francke (Open Source Business Alliance)
Keith Ganger (Lockheed Martin)
Jerod Heck (Lockheed Martin)
Mike Hepple (Apple)
Jannis Hermanns (Apple)
Jonathan Howard (Lockheed Martin)
Dustin Ingram (Google)
Jan Kowalleck (OWASP)
Philippe Ombredanne (AboutCode)
Dennis Roellke (Bloomberg)
Matt Rutkowski (IBM)

TC54-TG1 – Transparency exchange API

Scope:

Ecma TC54-TG1 is chartered to develop and maintain a standardized, format-agnostic API that enables the efficient discovery and exchange of Bills of Materials (BOMs) and other related artifacts between systems. The API will facilitate the handling of sensitive data, supply chain intelligence, and provide a standardized mechanism to publish, distribute, consume, and control access to all parties in the software supply chain.

Programme of work:

1. To develop a standard for the transparency exchange API (project Koala) for discovering and sharing of software transparency information.
2. To define the API architecture and data models, incorporating elements such as xBOM, CDXA, VDR/VEX, CLE, and insights.
3. To develop specifications for each component, focusing on security, scalability, and performance.

Officers:

Convenor

Steve Springett (ServiceNow)

Secretary

Samina Husain (Ecma International)

Members

Jan Kowalleck (OWASP)

TC54-TG2 – Package URL

Scope:

Ecma TC54-TG2 is chartered with the standardization of Package URL (PURL). The scope of this task group will include:

- PURL specification: development and maintenance of the PURL standard, which provides a clear and concise method for identifying packages across various package management systems.
- VERS specification: establishment and standardization of VERS, a specification designed to consistently represent version ranges, providing a uniform approach to managing version constraints across different programming environments and package managers.
- PURL types: standardization of PURL types, which categorize packages by their respective package management systems, ensuring that PURL remains flexible and comprehensive in covering various types of packages.

Community interaction and review: Engage with the software development community to gather feedback, review new PURL type requests, and ensure the PURL specifications remain relevant and effective in addressing the needs of package management systems and software developers

Programme of work:

1. To develop a standard for the PURL and VERS specifications.
2. To define a clear and transparent process for the standardization of new PURL types, including criteria for evaluation and approval.
3. To implement an ongoing review process for new PURL type proposals from the community, ensuring they meet the established criteria and contribute positively to the ecosystem.
4. To establish a governance process specific to PURL types.
5. To establish a release management process for the completion of PURL types.

Officers:

Convenor

Philippe Ombredanne (AboutCode)

Secretary

Samina Husain (Ecma International)

Members

Dustin Ingram (Google)

Steve Springett (ServiceNow)

TC54-TG3 – Common Lifecycle Enumeration

Scope:

Ecma TC54-TG3 is chartered with the standardization of the Common Lifecycle Enumeration (CLE), an open specification designed to support the aliasing of components and communicate lifecycle events such as end-of-life (EOL), end-of-support (EOS), and changes in component provenance over time. The CLE will provide a structured and machine-readable format to communicate lifecycle events and milestones for software and hardware components. The scope of this task group will include:

Objectives

- **Standardise Lifecycle Event Tracking:** Develop a consistent, machine-readable format for communicating lifecycle events (such as end-of-life, end-of-support, and component aliasing) that can be easily integrated into supply chain security tools and processes.
- **Resolve Component Aliasing Issues:** Create a framework to address the challenges of component aliasing, ensuring that software and hardware components are accurately identified across different lifecycle stages, even when names, manufacturers, or distributions change.
- **Ensure Compatibility with Existing Standards:** Align CLE with existing standards (e.g., PURL, VERS, CycloneDX, TEA) to ensure interoperability and widespread industry adoption of lifecycle event tracking.

Programme of work:

1. To develop a standard for the CLE specification..
2. To develop a prototype framework to resolve component aliases, ensuring accurate tracking of changing identifiers and names.
3. To develop and publish best practices for successful CLE adoption and integration with existing tools and standards.

Officers:

Convener

Jordan Harband (HeroDevs)
Steve Springett (ServiceNow)

Secretary

Samina Husain (Ecma International)

Members

TC55 – Web-interoperable server runtimes

Scope:

To define, refine, and standardize a “minimum common API” surface, along with a verifiable definition of compliance to that API, that is useful for improving interoperability across multiple ECMAScript environments which expand beyond web browsers, specifically web servers. The minimum common API does not replace or modify existing standards; all development efforts on other standards are carried out within their respective associated standards body.

In addition, TC55 may standardize new APIs that do not overlap with existing web platform APIs, specifically for capabilities that are relevant to server and server-like ECMAScript environments (such as general purpose web servers), such as interactions with host environments, e.g., command-line arguments and environment variables.

To aid in achieving these objectives, TC55 operates under the [Royalty-Free Patent Policy](#). Ecma TC55 may be informally referred to as “WinterTC”.

Programme of work:

1. Standardize and maintain a minimum common API consisting of a curated collection of web standard interfaces which form a common base to be supported by all “minimum common API compliant” environments, targeted at ECMAScript server runtimes.
2. Collect and document the requirements of non-web browser minimum common API compliant environments as input/feedback to the development of other standards developed either elsewhere within Ecma Technical Committees or other relevant standards bodies, working groups, and community groups – in particular the W3C and WHATWG. These requirements may be published as Ecma Technical Reports.
3. Should it become necessary, the committee will develop and standardize new APIs for capabilities relevant to server and server-like runtimes which have requirements beyond the scope of web platform standards and core language capabilities (defined in TC39). TC55 will prioritize working with existing web standards and existing standards Working Groups and Technical Committees over publishing novel standards.
4. Standardize and maintain conformance levels that group web APIs and novel standards. The first conformance level is the minimum common API. Further conformance levels exceed the minimum common API and may be relevant to servers only.
5. Produce and maintain a clear and verifiable definition of compliance to every conformance level and novel publication.

Officers:

Chair

Luca Casonato (Deno Land)

Vice-Chair

Andreu Botella (Igalia)

Secretaries

Aki Rose Braun (Ecma International), Samina Husain (Ecma International)

Members

Daniel Ehrenberg (Bloomberg)

James Snell (Cloudflare)

TC56 – Natural language interaction protocol for communication with Artificial Intelligence (AI) agents

Scope:

- The TC specifies a common protocol, framework and interfaces for interactions between AI agents using natural language while supporting multiple modalities.
- The framework for communication will include non-AI systems (e.g. clients on phones or hand-held devices without access to Large Language Models (LLMs)) talking to AI-agents (using generative AI, LLMs or traditional AI models), as well as interaction between two or more AI agents.
- The framework will specify conventions and best practices for end-points to enable secure and efficient implementations of the protocol.

To aid in achieving these objective, TC56 operates under the [Royalty-Free Patent Policy](#).

Programme of work:

1. To develop and maintain Standards and Technical Reports for a protocol for inter-agent communication.
2. To develop and maintain best practices for end-point implementations of the protocol.
3. To monitor related standardization activities to avoid duplication, to promote synergies and to promote complementary efforts via internal and external liaisons with – and contribute to – the work of international SDOs.

Officers:

Chair

Dinesh Verma (IBM)

Vice-Chair

Elisa Bertino (Purdue University)

Secretaries

Luyi Xing (Indiana University), Patrick Lüthi (Ecma International)

Members

Sanjay Aiyagari (IBM)
Erik Erlandson (IBM)
Sean Hughes (ServiceNow)
Yohei Kawaguchi (Hitachi)
Jon Lenchner (IBM)
Abhay Ratnaparkhi (IBM)
Amit Tiwari (Microsoft)

Index of Ecma Standards

This index contains the following categories: General, software engineering and interfaces, data presentation, data communication, data interchange and archiving by physical media, access systems and interconnection, wireless proximity systems, multimedia.

Environmental

Energy consumption, environmental conscious design & environmental product attributes	ECMA-328	ECMA-389
	ECMA-341	ECMA-393
	ECMA-370	ECMA-400
	ECMA-383	

Acoustical emissions	ECMA-74	ECMA-275
	ECMA-108	ECMA-418
	ECMA-109	ECMA-425
	ECMA-160	

Safety, EMC and EMF	ECMA-287	ECMA-358
----------------------------	----------	----------

Software engineering and interfaces

PCTE	ECMA-149	ECMA-230
	ECMA-158	ECMA-270
	ECMA-162	
API	ECMA-234	ECMA-419
ECMAScript®	ECMA-262	ECMA-414
	ECMA-402	ECMA-426
Programming languages	ECMA-334	ECMA-404
	ECMA-335	ECMA-408
	ECMA-367	ECMA-422
	ECMA-372	
Bill of materials	ECMA-424	

Data presentation

Character sets and coding	ECMA-6	ECMA-114
	ECMA-35	ECMA-118
	ECMA-43	ECMA-121
	ECMA-48	ECMA-128
	ECMA-94	ECMA-144
	ECMA-113	
Labelling, volume and file structure	ECMA-13	ECMA-167
	ECMA-107	ECMA-168
	ECMA-119	ECMA-208

Data communication

PISN	ECMA-106	ECMA-253
	ECMA-133	ECMA-254
	ECMA-142	ECMA-261
	ECMA-143	ECMA-263
	ECMA-148	ECMA-264
	ECMA-155	ECMA-265
	ECMA-156	ECMA-266
	ECMA-157	ECMA-276
	ECMA-161	ECMA-277
	ECMA-163	ECMA-281
	ECMA-164	ECMA-282
	ECMA-165	ECMA-283
	ECMA-173	ECMA-284
	ECMA-174	ECMA-289
	ECMA-175	ECMA-294
	ECMA-176	ECMA-295
	ECMA-177	ECMA-296
	ECMA-178	ECMA-297
	ECMA-185	ECMA-298
	ECMA-186	ECMA-299
ECMA-191	ECMA-300	

	ECMA-192	ECMA-301
	ECMA-193	ECMA-302
	ECMA-194	ECMA-303
	ECMA-202	ECMA-304
	ECMA-203	ECMA-305
	ECMA-211	ECMA-306
	ECMA-212	ECMA-310
	ECMA-213	ECMA-311
	ECMA-214	ECMA-312
	ECMA-220	ECMA-313
	ECMA-221	ECMA-314
	ECMA-224	ECMA-318
	ECMA-225	ECMA-324
	ECMA-226	ECMA-325
	ECMA-232	ECMA-333
	ECMA-241	ECMA-336
	ECMA-242	ECMA-339
	ECMA-244	ECMA-343
	ECMA-245	ECMA-344
	ECMA-250	ECMA-345
	ECMA-251	ECMA-346
	ECMA-252	ECMA-347
CSTA	ECMA-179	ECMA-285
	ECMA-180	ECMA-323
	ECMA-217	ECMA-348
	ECMA-218	ECMA-354
	ECMA-269	ECMA-366
IT-security	ECMA-205	ECMA-235
	ECMA-206	ECMA-271
	ECMA-219	
Corporate telecommunication networks	ECMA-307	ECMA-332
	ECMA-308	ECMA-355
	ECMA-309	ECMA-360
	ECMA-326	ECMA-361

Data interchange and archiving by physical media

Flexible disk cartridges	ECMA-99	ECMA-147
	ECMA-100	ECMA-207
	ECMA-125	
Magnetic tapes and cartridges	ECMA-120	ECMA-246
	ECMA-139	ECMA-247
	ECMA-145	ECMA-248
	ECMA-146	ECMA-249
	ECMA-150	ECMA-258
	ECMA-152	ECMA-259
	ECMA-169	ECMA-278
	ECMA-170	ECMA-286
	ECMA-171	ECMA-288
	ECMA-182	ECMA-291
	ECMA-196	ECMA-292
	ECMA-197	ECMA-293
	ECMA-198	ECMA-315
	ECMA-209	ECMA-316
	ECMA-210	ECMA-319
	ECMA-231	ECMA-320
	ECMA-236	ECMA-329
Optical disks and cartridges	ECMA-130	ECMA-331
	ECMA-153	ECMA-337
	ECMA-154	ECMA-338
	ECMA-183	ECMA-349
	ECMA-184	ECMA-350
	ECMA-189	ECMA-351
	ECMA-190	ECMA-353
	ECMA-195	ECMA-359
	ECMA-201	ECMA-364
	ECMA-223	ECMA-365
	ECMA-238	ECMA-371



	ECMA-239	ECMA-374
	ECMA-240	ECMA-379
	ECMA-260	ECMA-380
	ECMA-267	ECMA-382
	ECMA-268	ECMA-384
	ECMA-272	ECMA-394
	ECMA-273	ECMA-395
	ECMA-274	ECMA-396
	ECMA-279	ECMA-405
	ECMA-280	ECMA-406
	ECMA-317	ECMA-413
	ECMA-322	ECMA-421
	ECMA-330	
Holographic disks and cartridges	ECMA-375	ECMA-420
	ECMA-377	ECMA-423
	ECMA-378	
Data compression	ECMA-151	ECMA-222
	ECMA-159	ECMA-321
Access systems and interconnection		
	ECMA-342	ECMA-417
	ECMA-412	
Wireless proximity systems		
Near Field Communication	ECMA-340	ECMA-390
	ECMA-352	ECMA-391
	ECMA-356	ECMA-403
	ECMA-362	ECMA-409
	ECMA-373	ECMA-410
	ECMA-385	ECMA-411
	ECMA-386	ECMA-415
High Rate Wireless Communication	ECMA-368	ECMA-397
	ECMA-369	ECMA-398
	ECMA-381	ECMA-399
	ECMA-387	ECMA-401
	ECMA-392	
Multimedia		
Universal 3D Audio coding	ECMA-363	ECMA-416
	ECMA-407	
Document architecture		
	ECMA-376	ECMA-388

Ecma Standards and corresponding International and European Standards

In the third column of the table below you can find:

- the ISO/IEC equivalent to the Ecma Standard which can be downloaded as freely available standard from [ISO/IEC](#)
- the ETSI equivalent to the Ecma Standard which can be downloaded as limitedly freely available publication from [ETSI](#)

Legend:

ISO	International Standard published by ISO
IEC	International Standard published by IEC
ISO/IEC	International Standard published by ISO and IEC
DIS	Draft International Standard
ETSI ETS	ETSI European Telecommunications Standard (previous nomenclature)
ETSI EN	European Standard (telecommunications series)
ETSI ES	ETSI Standard
ETSI TS	ETSI Technical Specification
ETSI EG	ETSI Guide
ETSI ETR	ETSI European Telecommunications Technical Report (previous nomenclature)
ETSI TR	ETSI Technical Report

The ETSI TS and TR are approved by the parent technical committee. The others deliverables are approved by the ETSI community. For more detailed information on ETSI deliverables, see the [ETSI directives](#).

Ecma Standards in force (electronically available [here](#))

ECMA-6	7-Bit Coded Character Set, 6 th edition (December 1991)	ISO/IEC 646
ECMA-13	File Structure and Labelling of Magnetic Tapes for Information Interchange, 4 th edition (December 1985)	ISO 1001
ECMA-35	Character Code Structure and Extension Techniques, 6 th edition (December 1994)	ISO/IEC 2022
ECMA-43	8-Bit Coded Character Set Structure and Rules 3 rd edition (December 1991)	ISO/IEC 4873
ECMA-48	Control Functions for Coded Character Sets, 5 th edition (June 1991)	ISO/IEC 6429
ECMA-74	Measurement of Airborne Noise emitted by Information Technology and Telecommunications Equipment, 20 th edition (December 2022)	ISO 7779
ECMA-94	8-Bit Single-Byte Coded Graphic Character Sets - Latin Alphabets No. 1 to No. 4, 2 nd edition (June 1986)	ISO 8859-1, -2, -3 and -4
ECMA-99	Data Interchange on 130 mm Flexible Disk Cartridges using MFM Recording at 13 262 fprad on Both Sides 3,8 Tracks per mm (September 1985)	ISO 8630
ECMA-100	Data Interchange on 90 mm Flexible Disk Cartridges using MFM Recording at 7 958 fprad on 80 Tracks on Each Side - ISO Type 301, 2 nd edition (December 1988)	ISO 8860
ECMA-106	Private Telecommunication Networks (PTN) - Signalling Protocol at the S Reference Point - Circuit Mode Basic Services (SSIG-BC), 3 rd edition (December 1993)	ETS 300 192
ECMA-107	Volume and File Structure of Disk Cartridges for Information Interchange, 2 nd edition (June 1995)	ISO/IEC 9293
ECMA-108	Determination of High-frequency Sound Power Levels Emitted by Information Technology and Telecommunications Equipment, 6 th edition (December 2016)	ISO 9295
ECMA-109	Declared Noise Emission Values of Information Technology and Telecommunications Equipment, 10 th edition (December 2020)	ISO 9296
ECMA-113	8-Bit Single-Byte Coded Graphic Character Sets - Latin/Cyrillic Alphabet, 3 rd edition (December 1999)	ISO 8859-5
ECMA-114	8-Bit Single-Byte Coded Graphic Character Sets - Latin/Arabic Alphabet, 2 nd edition (December 2000)	ISO 8859-6
ECMA-118	8-Bit Single-Byte Coded Graphic Character Sets - Latin/Greek Alphabet (December 1986)	ISO 8859-7
ECMA-119	Volume and File Structure of CDROM for Information Interchange, 5 th edition (December 2024)	ISO 9660
ECMA-120	Data Interchange on 12,7 mm 18-Track Magnetic Tape Cartridges, 3 rd edition (December 1993)	ISO 9661
ECMA-121	8-Bit Single-Byte Coded Graphic Character Sets - Latin/Hebrew Alphabet, 2 nd edition (December 2000)	ISO 8859-8
ECMA-125	Data Interchange on 90 mm Flexible Disk Cartridges using MFM Recording at 15 916 fprad on 80 Tracks on Each Side - ISO Type 302 (December 1987)	ISO 9529
ECMA-128	8-Bit Single-Byte Coded Graphic Character Sets - Latin Alphabet No. 5, 2 nd edition (December 1999)	ISO 8859-9
ECMA-130	Data Interchange on Read-only 120 mm Optical Data Disks (CD-ROM), 2 nd edition (June 1996)	ISO/IEC 10149

ECMA-133	Private Integrated Services Network (PISN) - Reference Configuration for PISN Exchanges (PINX), 2 nd edition (December 1998)	ISO/IEC 11579-1 ETS 300 475-1
ECMA-139	3,81 mm Wide Magnetic Tape Cartridge for Information Interchange - Helical Scan Recording - DDS Format (June 1990)	ISO/IEC 10777
ECMA-142	Private Integrated Services Network (PISN) - Circuit Mode 64kbit/s Bearer Services - Service Description, Functional Capabilities and Information Flows (BCSD), 3 rd edition (December 2001)	ISO/IEC 11574 EN 300 171
ECMA-143	Private Integrated Services Network (PISN) - Circuit Mode Bearer Services - Inter-Exchange Signalling Procedures and Protocol (QSIG-BC), 4 th edition (December 2001)	ISO/IEC 11572 EN 300 172
ECMA-144	8-Bit Single-Byte Coded Character Sets - Latin Alphabet No. 6, 3 rd edition (December 2000)	ISO/IEC 8859-10
ECMA-145	8 mm Wide Magnetic Tape Cartridge for Information Interchange - Helical Scan Recording (December 1990)	ISO/IEC 11319
ECMA-146	3,81 mm Wide Magnetic Tape Cartridge for Information Interchange - Helical Scan Recording - DATA/DAT Format (December 1990)	ISO/IEC 11321
ECMA-147	Data Interchange on 90 mm Flexible Disk Cartridges using MFM Recording at 31 831 fthead on 80 Tracks on Each Side - ISO Type 303 (December 1990)	ISO/IEC 10994
ECMA-148	Private Integrated Services Network (PISN) - Specification, Functional Model and Information Flows - Identification Supplementary Services (ISSD), 3 rd edition (June 1997)	ISO/IEC 14136 ETS 300 173
ECMA-149	Portable Common Tool Environment (PCTE) - Abstract Specification, 4 th edition (December 1997)	ISO/IEC 13719-1
ECMA-150	3,81 mm Wide Magnetic Tape Cartridge for Information Interchange - Helical Scan Recording - DDS-DC Format using 60 m and 90 m Length Tapes, 2 nd edition (June 1992)	ISO/IEC 11557
ECMA-151	Data Compression for Information Interchange - Adaptive Coding with Embedded Dictionary - DCLZ Algorithm (June 1991)	ISO/IEC 11558
ECMA-152	Data Interchange on 12,7 mm 18-Track Magnetic Tape Cartridges - Extended Format, 2 nd edition (December 1993)	ISO/IEC 11559
ECMA-153	Information Interchange on 130 mm Optical Disk Cartridges of the Write Once, Read Multiple (WORM) Type, using the Magneto-Optical Effect, 2 nd edition (June 1994)	ISO/IEC 11560
ECMA-154	Data Interchange on 90 mm Optical Disk Cartridges, Read Only and Rewritable, M.O., 2 nd edition (June 1994)	ISO/IEC 10090
ECMA-155	Private Integrated Services Networks - Addressing, 2 nd edition (June 1997)	ISO/IEC 11571 EN 300 189
ECMA-156	Private Telecommunication Networks (PTN) - Signalling at the S Reference Point - Generic Keypad Protocol for the Support of Supplementary Services (SSIG-KP), 2 nd edition (June 1993)	ETS 300 190
ECMA-157	Private Telecommunication Networks (PTN) - Signalling Protocol at the S Reference Point - Identification Supplementary Services (SSIG-ID), 2 nd edition (June 1993)	ETS 300 191

ECMA-158	Portable Common Tool Environment (PCTE) - C Programming Language Binding, 4 th edition (December 1997)	ISO/IEC 13719-2
ECMA-159	Data Compression for Information Interchange - Binary Arithmetic Coding Algorithm (December 1991)	ISO/IEC 12042
ECMA-160	Determination of Sound Power Levels of Computer and Business Equipment using Sound Intensity Measurements; Scanning Method in Controlled Rooms, 2 nd edition (December 1992)	ISO 9614-2
ECMA-161	Private Telecommunication Networks (PTN) - Signalling at the S Reference Point - Generic Feature Key Management Protocol for the Control of Supplementary Services (SSIG-FK), 2 nd edition (June 1993)	ETS 300 240
ECMA-162	Portable Common Tool Environment (PCTE) - Ada Programming Language Binding, 4 th edition (December 1997)	ISO/IEC 13719-3
ECMA-163	Private Integrated Services Network (PISN) - Specification, Functional Model and Information Flows - Name Identification Supplementary Services (NISD), 3 rd edition (September 1997)	ISO/IEC 13864 ETS 300 237
ECMA-164	Private Integrated Services Network (PISN) - Inter-Exchange Signalling Protocol - Name Identification Supplementary Services (QSIG-NA), 4 th edition (December 2001)	ISO/IEC 13868 ETS 300 238
ECMA-165	Private Integrated Services Network (PISN) - Generic Functional Protocol for the Support of Supplementary Services - Inter-Exchange Signalling Procedures and Protocol (QSIG-GF), 4 th edition (June 2001)	ISO/IEC 11582 ETS 300 239
ECMA-167	Volume and File Structure for Write-Once and Rewritable Media using Non-Sequential Recording for Information Interchange, 3 rd edition (June 1997)	ISO/IEC 13346
ECMA-168	Volume and File Structure of Read-Only and Write-Once Compact Disk Media for Information Interchange, 2 nd edition (December 1994)	ISO/IEC 13490
ECMA-169	8 mm Wide Magnetic Tape Cartridge Dual Azimuth Format for Information Interchange - Helical Scan Recording (June 1992)	ISO/IEC 12246
ECMA-170	3,81 mm Wide Magnetic Tape Cartridge for Information Interchange - Helical Scan Recording - DDS Format using 60 m and 90 m Length Tapes (June 1992)	ISO/IEC 12247
ECMA-171	3,81 mm Wide Magnetic Tape Cartridge for Information Interchange - Helical Scan Recording - DATA/DAT-DC Format using 60 m and 90 m Length Tapes (June 1992)	ISO/IEC 12248
ECMA-173	Private Integrated Services Network (PISN) - Specification, Functional Model and Information Flows - Call Diversion Supplementary Services (CFSD), 3 rd edition (December 2001)	ISO/IEC 13872 ETS 300 256
ECMA-174	Private Integrated Services Network (PISN) - Inter-Exchange Signalling Protocol - Call Diversion Supplementary Services (QSIG-CF), 3 rd edition (December 2001)	ISO/IEC 13873 ETS 300 257
ECMA-175	Private Integrated Services Network (PISN) - Specification, Functional Model and Information Flows - Path Replacement Additional Network Feature (ANF-PRSD), 3 rd edition (December 1998)	ISO/IEC 13863 ETS 300 258
ECMA-176	Private Integrated Services Network (PISN) - Inter-exchange Signalling Protocol - Path Replacement Additional Network Feature (QSIG-PR), 4 th edition (December 2001)	ISO/IEC 13874 ETS 300 259

ECMA-177	Private Integrated Services Network (PISN) - Specification, Functional Model and Information Flows - Call Transfer Supplementary Service (CTSD), 3 rd edition (December 2001)	ISO/IEC 13865 ETS 300 260
ECMA-178	Private Integrated Services Network (PISN) - Inter-Exchange Signalling Protocol - Call Transfer Supplementary Service (QSIG-CT), 3 rd edition (December 2001)	ISO/IEC 13869 ETS 300 261
ECMA-179	Services for Computer Supported Telecommunications Applications (CSTA) Phase I (June 1992)	
ECMA-180	Protocol for Computer Supported Telecommunications Applications (CSTA) Phase I (June 1992)	
ECMA-182	Data Interchange on 12,7 mm 48 Track Magnetic Tape Cartridges - DLT1 Format (December 1992)	ISO/IEC 13421
ECMA-183	Data Interchange on 130 mm Optical Disk Cartridges - Capacity: 1 Gigabyte per Cartridge (December 1992)	ISO/IEC 13481
ECMA-184	Data Interchange on 130 mm Optical Disk Cartridges - Capacity: 1,3 Gigabytes per Cartridge (December 1992)	ISO/IEC 13549
ECMA-185	Private Integrated Services Network (PISN) - Specification, Functional Model and Information Flows - Call Completion Supplementary Services (CCSD), 2 nd edition (June 1997)	ISO/IEC 13866 ETS 300 365
ECMA-186	Private Integrated Services Network (PISN) - Inter-Exchange Signalling Protocol - Call Completion Supplementary Services (QSIG-CC), 4 th edition (December 2001)	ISO/IEC 13870 ETS 300 366
ECMA-189	Information Interchange on 300 mm Optical Disk Cartridges of the Write Once, Read Multiple (WORM) Type using the SSF Method (June 1993)	ISO/IEC 13614
ECMA-190	Information Interchange on 300 mm Optical Disk Cartridges of the Write Once, Read Multiple (WORM) Type using the CCS Method (June 1993)	ISO/IEC 13403
ECMA-191	Private Integrated Services Network (PISN) - Specification, Functional Model and Information Flows - Call Offer Supplementary Service (COSD), 2 nd edition (June 1997)	ISO/IEC 14841 EN 300 361
ECMA-192	Private Integrated Services Network (PISN) - Inter-Exchange Signalling Protocol - Call Offer Supplementary Service (QSIG-CO), 4 th edition (December 2001)	ISO/IEC 14843 EN 300 362
ECMA-193	Private Integrated Services Network (PISN) - Specification, Functional Model and Information Flows - Do Not Disturb and Do Not Disturb Override Supplementary Services (DND(O)SD), 2 nd edition (June 1997)	ISO/IEC 14842 EN 300 363
ECMA-194	Private Integrated Services Network (PISN) - Inter-Exchange Signalling Protocol - Do Not Disturb and Do Not Disturb Override Supplementary Services (QSIG-DND(O)), 4 th edition (December 2001)	ISO/IEC 14844 EN 300 364
ECMA-195	Data Interchange on 130 mm Optical Disk Cartridges - Capacity: 2 Gigabytes per Cartridge, 2 nd edition (June 1995)	ISO/IEC 13842
ECMA-196	Data Interchange on 12,7 mm 36-Track Magnetic Tape Cartridges (December 1993)	ISO/IEC 14251
ECMA-197	Data Interchange on 12,7 mm 112-Track Magnetic Tape Cartridges - DLT2 Format (December 1993)	ISO/IEC 13962

ECMA-198	3,81 mm Wide Magnetic Tape Cartridge for Information Interchange - Helical Scan Recording - DDS-2 Format using 120 m Length Tapes, 2 nd edition (June 1995)	ISO/IEC 13923
ECMA-201	Data Interchange on 90 mm Optical Disk Cartridges - Capacity: 230 Megabytes per Cartridge, 2 nd edition (December 1994)	ISO/IEC 13963
ECMA-202	Private Integrated Services Network (PISN) - Specification, Functional Model and Information Flows - Call Intrusion Supplementary Service (CISD), 2 nd edition (June 1997)	ISO/IEC 14845 EN 300 425
ECMA-203	Private Integrated Services Network (PISN) - Inter-Exchange Signalling Protocol - Call Intrusion Supplementary Service (QSIG-CI), 4 th edition (December 2001)	ISO/IEC 14846 EN 300 426
ECMA-205	Commercially Oriented Functionality Class for Security Evaluation (COFC) (December 1993)	
ECMA-206	Association Context Management including Security Context Management (December 1993)	
ECMA-207	Data Interchange on 90 mm Flexible Disk Cartridges - 326 Data Tracks on each Side - Capacity: 21 Mbytes - ISO Type 305 (June 1994)	ISO/IEC 14169
ECMA-208	System-Independent Data Format - SIDF (December 1994)	ISO/IEC 14863
ECMA-209	Data Interchange on 12,7 mm 128-Track Magnetic Tape Cartridges - DLT3 Format (December 1994)	ISO/IEC 14833
ECMA-210	12,65 mm Wide Magnetic Tape Cartridge for Information Interchange - Helical Scan Recording - DATA-D3-1 Format, 2 nd edition (December 1995)	ISO/IEC 14840
ECMA-211	Private Integrated Services Network (PISN) - Specification, Functional Model and Information Flows - Advice of Charge Supplementary Services (AOCS), 3 rd edition (December 2001)	ISO/IEC 15049 EN 301 254
ECMA-212	Private Integrated Services Network (PISN) - Inter-Exchange Signalling Protocol - Advice of Charge Supplementary Services (QSIG-AOC), 3 rd edition (December 2001)	ISO/IEC 15050 EN 301 264
ECMA-213	Private Integrated Services Network (PISN) - Specification, Functional Model and Information Flows - Recall Supplementary Service (RES), 3 rd edition (December 2001)	ISO/IEC 15051 EN 301 257
ECMA-214	Private Integrated Services Network (PISN) - Inter-Exchange Signalling Protocol - Recall Supplementary Service (QSIG-RE), 3 rd edition (December 2001)	ISO/IEC 15052 EN 301 258
ECMA-217	Services for Computer Supported Telecommunications Applications (CSTA) Phase II (December 1994)	
ECMA-218	Protocol for Computer Supported Telecommunications Applications (CSTA) Phase II (December 1994)	
ECMA-219	Authentication and Privilege Attribute Security Application with Related Key Distribution Functions - Part 1, 2 and 3, 2 nd edition (March 1996)	
ECMA-220	Private Integrated Services Network (PISN) - Specification, Functional Model and Information Flows - Call Interception Additional Network Feature (ANF-CINTSD), 3 rd edition (December 2001)	ISO/IEC 15053 EN 301 256

ECMA-221	Private Integrated Services Network (PISN) - Inter-Exchange Signalling Protocol - Call Interception Additional Network Feature (QSIG-CINT), 3 rd edition (December 2001)	ISO/IEC 15054 EN 301 265
ECMA-222	Adaptive Lossless Data Compression Algorithm (June 1995)	ISO/IEC 15200
ECMA-223	Data Interchange on 90 mm Optical Disk Cartridges - Capacity: 385 Megabytes per Cartridge (June 1995)	
ECMA-224	Private Integrated Services Network (PISN) - Specification, Functional Model and Information Flows - Transit Counter Additional Network Feature (ANF-TCSD), 2 nd edition (June 1997)	ISO/IEC 15055 EN 301 047
ECMA-225	Private Integrated Services Network (PISN) - Inter-Exchange Signalling Protocol - Transit Counter Additional Network Feature (QSIG-TC), 2 nd edition (June 1997)	ISO/IEC 15056 EN 301 048
ECMA-226	Private Integrated Services Network (PISN) - Mapping Functions for the Employment of Dedicated Circuit Mode Connections as Inter-PTNX Connections (MAPPING-CM-STATIC) (June 1995)	EN 301 765
ECMA-230	Portable Common Tool Environment (PCTE) - IDL Binding (Interface Definition Language), 2 nd edition (December 1997)	ISO/IEC 13719-4
ECMA-231	Data Interchange on 12,7 mm 128-Track Magnetic Tape Cartridges - DLT 4 Format (December 1995)	ISO/IEC 15307
ECMA-232	Private Integrated Services Network (PISN) - Profile Standard for the Connection of Radio Paging Equipment (RPE) to a PISN (December 1995)	ETS 300 739
ECMA-234	Application Programming Interface for Windows (APIW) (December 1995)	
ECMA-235	The ECMA GSS-API Mechanism (March 1996)	
ECMA-236	3,81 mm Wide Magnetic Tape Cartridge for Information Interchange - Helical Scan Recording - DDS-3 Format using 125 m Length Tapes (June 1996)	ISO/IEC 15521
ECMA-238	Data Interchange on 130 mm Optical Disk Cartridge of Type WORM (Write Once Read Many) using Irreversible Effects - Capacity: 2,6 Gbytes per Cartridge (June 1996)	ISO/IEC 15486
ECMA-239	Data Interchange on 90 mm Optical Disk Cartridges - HS-1 Format - Capacity: 650 Megabytes per Cartridge (June 1996)	ISO/IEC 15498
ECMA-240	Data Interchange on 120 mm Optical Disk Cartridges using Phase Change PD Format - Capacity: 650 Mbytes per Cartridge (June 1996)	ISO/IEC 15485
ECMA-241	Private Integrated Services Network (PISN) - Specification, Functional Model and Information Flows - Message Waiting Indication Supplementary Service (MWISD), 4 th edition (February 2002)	ISO/IEC 15505 EN 301 260
ECMA-242	Private Integrated Services Network (PISN) - Inter-Exchange Signalling Protocol - Message Waiting Indication Supplementary Service (QSIG-MWI), 4 th edition (December 2001)	ISO/IEC 15506 EN 301 255
ECMA-244	Private Integrated Services Network (PISN) - Mapping Functions for the Employment of a Circuit Mode Basic Service and the Supplementary Service User-to-User Signalling as a pair of On-demand Inter-PINX Connections (Mapping-UUS), 2 nd edition (September 2000)	ISO/IEC 17309 EN 301 102

ECMA-245	Private Integrated Services Network (PISN) - Inter-Exchange Signalling Protocol - PINX Clock Synchronization (SYNC-SIG), 2 nd edition (September 1997)	ISO/IEC 15507 EN 301 259
ECMA-246	8 mm Wide Magnetic Tape Cartridge for Information Interchange - Helical Scan Recording - AIT-1 Format, 2 nd edition (June 1998)	ISO/IEC 15780
ECMA-247	8 mm Wide Magnetic Tape Cartridge for Information Interchange - Helical Scan Recording - HH-1 Format, 2 nd edition (June 1998)	ISO/IEC 15718
ECMA-248	12,65 mm Wide Magnetic Tape Cassette for Information Interchange - Helical Scan Recording - DTF-1 Format, 2 nd edition (June 1998)	ISO/IEC 15731
ECMA-249	8 mm Wide Magnetic Tape Cartridge for Information Interchange - Helical Scan Recording - DA-2 Format, 2 nd edition (June 1998)	ISO/IEC 15757
ECMA-250	Private Integrated Services Network (PISN) - Specification, Functional Model and Information Flows - Common Information Additional Network Feature (ANF-CMNSD), 2 nd edition (December 1998)	ISO/IEC 15771 EN 301 819
ECMA-251	Private Integrated Services Network (PISN) - Inter-Exchange Signalling Protocol - Common Information Additional Network Feature (QSIG-CMN), 3 rd edition (December 2001)	ISO/IEC 15772 EN 301 820
ECMA-252	Broadband Private Integrated Services Network (B-PISN) - Inter-Exchange Signalling Protocol - Transit Counter Additional Network Feature (B-QSIG-TC) (December 1996)	ISO/IEC 15773
ECMA-253	Private Integrated Services Network (PISN) - Mapping Functions for the Employment of 64 kbit/s Circuit Mode Connection with 16 kbit/s Sub-multiplexing (Mapping/16), 2 nd edition (September 2000)	ISO/IEC 17310 EN 301 039
ECMA-254	Broadband Private Integrated Services Network (B-PISN) - Inter-Exchange Signalling Protocol - Generic Functional Protocol (B-QSIG-GF), 2 nd edition (December 1999)	ISO/IEC 19058
ECMA-258	Data Interchange on 12,7 mm 128-Track Magnetic Tape Cartridges - DLT 3-XT Format (June 1997)	ISO/IEC 15895
ECMA-259	Data Interchange on 12,7 mm 208-Track Magnetic Tape Cartridges - DLT 5 Format (June 1997)	ISO/IEC 15896
ECMA-260	Data Interchange on 356 mm Optical Disk Cartridges - WORM, using Phase Change Technology Capacity: 14,8 and 25 Gbytes per Cartridge (June 1997)	ISO/IEC 15898
ECMA-261	Broadband Private Integrated Services Network (B-PISN) - Service Description - Broadband Connection Oriented Bearer Services (B-BCSD) (June 1997)	ISO/IEC 15899
ECMA-262	ECMAScript® 2024 Language Specification, 15 th edition (June 2024)	
ECMA-263	Private Integrated Services Network (PISN) - Specification, Functional Model and Information Flows - Call Priority Interruption and Call Priority Interruption Protection Supplementary Services (CPI(P)SD), 3 rd edition (December 2001)	ISO/IEC 15991 EN 301 655
ECMA-264	Private Integrated Services Network (PISN) - Inter-Exchange Signalling Protocol - Call Priority Interruption and Call Priority Interruption Protection Supplementary Services (QSIG-CPI(P)), 3 rd edition (December 2001)	ISO/IEC 15992 EN 301 656

ECMA-265	Broadband Private Integrated Services Network (B-PISN) - Inter-Exchange Signalling Protocol - Signalling ATM Adaptation Layer (B-QSIG-SAAL) (September 1997)	ISO/IEC 13246
ECMA-266	Broadband Private Integrated Services Network (B-PISN) - Inter-Exchange Signalling Protocol - Basic Call/Connection Control (B-QSIG-BC) (September 1997)	ISO/IEC 13247
ECMA-267	120 mm DVD - Read-Only Disk, 3 rd edition (April 2001)	ISO/IEC 16448
ECMA-268	80 mm DVD - Read-Only Disk, 3 rd edition (April 2001)	ISO/IEC 16449
ECMA-269	Services for Computer Supported Telecommunications Applications (CSTA) Phase III, 9 th edition (December 2011)	ISO/IEC 18051 TS 102 173
ECMA-270	Portable Common Tool Environment (PCTE) - Mapping from CASE Data Interchange Format (CDIF) to PCTE (December 1997)	
ECMA-271	Extended Commercially Oriented Functionality Class for Security Evaluation (E-COFC), 2 nd edition (December 1999)	
ECMA-272	120 mm DVD Rewritable Disk (DVD-RAM), 2 nd edition (June 1999)	ISO/IEC 16824
ECMA-273	Case for 120 mm DVD-RAM Disks (February 1998)	ISO/IEC 16825
ECMA-274	Data Interchange on 120 mm Optical Disk using +RW Format - Capacity: 3,0 Gbytes and 6,0 Gbytes, 2 nd edition (June 1999)	ISO/IEC 16969
ECMA-275	Measurement of structure-borne vibration induced by small air moving devices (AMDs), 5 th edition (December 2020)	
ECMA-276	Private Integrated Services Network (PISN) - Reference Configuration for PINX Extension Lines (June 1998)	ISO/IEC 11579-3
ECMA-277	Private Integrated Services Network (PISN) - Circuit Emulation Specification - Emulation of Basic Access by ATM Networks (June 1998)	
ECMA-278	Data Interchange on 12,7 mm 128-Track Magnetic Tape Cartridge - Parallel Serpentine Format, 2 nd edition (June 2000)	ISO/IEC 17913
ECMA-279	80 mm (1,23 Gbytes per side) and 120 mm (3,95 Gbytes per side) DVD-Recordable Disk (DVD-R) (December 1998)	ISO/IEC 20563
ECMA-280	Data Interchange on 130 mm Optical Disk Cartridges of Type WORM (Write Once Read Many) using Irreversible Effects - Capacity: 5,2 Gbytes per Cartridge (December 1998)	ISO/IEC 18093
ECMA-281	Private Integrated Services Network (PISN) - Specification, Functional Model and Information Flows - Private User Mobility (PUM) - Registration Supplementary Service (PUMRSD), 3 rd edition (December 2001)	ISO/IEC 17875 EN 301 822
ECMA-282	Private Integrated Services Network (PISN) - Inter-Exchange Signalling Protocol - Private User Mobility (PUM) - Registration Supplementary Service (QSIG-PUMR), 3 rd edition (December 2001)	ISO/IEC 17876 EN 301 821
ECMA-283	Private Integrated Services Network (PISN) - Specification, Functional Model and Information Flows - Private User Mobility (PUM) - Call Handling Additional Network Features (PUMCHSD), 2 nd edition (June 2000)	ISO/IEC 17877 EN 301 657

ECMA-284	Private Integrated Services Network (PISN) - Inter-Exchange Signalling Protocol - Private User Mobility (PUM) - Call Handling Additional Network Features (QSIG-PUMCH), 3 rd edition (December 2001)	ISO/IEC 17878 EN 301 810
ECMA-285	ASN.1 for Computer Supported Telecommunications Applications (CSTA) Phase III, 4 th edition (December 2011)	ISO/IEC 18052
ECMA-286	Data Interchange on 12,7 mm 208-Track Magnetic Tape Cartridges - DLT 6 Format, 2 nd edition (June 2000)	ISO/IEC 16382
ECMA-287	Safety of electronic equipment, 2 nd edition (December 2002)	
ECMA-288	3,81 mm Wide Magnetic Tape Cartridge for Information Interchange - Helical Scan Recording - DDS-4 Format (June 1999)	ISO/IEC 17462
ECMA-289	Private Integrated Services Network (PISN) - Mapping Functions for the Employment of 64 kbit/s Circuit Mode Connections with 8 kbit/s Sub-Multiplexing (Mapping/8), 2 nd edition (September 2000)	ISO/IEC 17311 EN 301 924
ECMA-291	8 mm Wide Magnetic Tape Cartridge for Information Interchange - Helical Scan Recording AIT-1 with MIC Format (December 1999)	ISO/IEC 18809
ECMA-292	8 mm Wide Magnetic Tape Cartridge for Information Interchange - Helical Scan Recording AIT-2 with MIC Format (December 1999)	ISO/IEC 18810
ECMA-293	8 mm Wide Magnetic Tape Cartridge for Information Interchange - Helical Scan Recording - MammothTape-2 Format (December 1999)	ISO/IEC 18836
ECMA-294	B-ISDN and B-PISN - Digital Subscriber Signalling System No. two (DSS2), Broadband Inter-Exchange Signalling (B-QSIG), and Signalling System No. 7 (SS7) - Call Control in a Separated Call and Bearer Control Environment - Part 1: Protocol Specification (December 1999)	EN 302 092-1
ECMA-295	B-ISDN and B-PISN - Digital Subscriber Signalling System No. two (DSS2), Broadband Inter-Exchange Signalling (B-QSIG), and Signalling System No. 7 (SS7) - Call Control in a Separated Call and Bearer Control Environment - Part 2: Protocol Implementation Conformance Statement (PICS) Proforma Specification (December 1999)	EN 302 092-2
ECMA-296	B-ISDN and B-PISN - Digital Subscriber Signalling System No. two (DSS2), Broadband Inter-Exchange Signalling (B-QSIG), and Signalling System No. 7 (SS7) - Prenegotiation - Part 1: Protocol Specification (December 1999)	EN 302 091-1
ECMA-297	B-ISDN and B-PISN - Digital Subscriber Signalling System No. two (DSS2), Broadband Inter-Exchange Signalling (B-QSIG), and Signalling System No. 7 (SS7) - Prenegotiation - Part 2: Protocol Implementation Conformance Statement (PICS) Proforma Specification (December 1999)	EN 302 091-2
ECMA-298	Broadband Private Integrated Services Network (B-PISN) - Inter-Exchange Signalling Protocol - Separated Bearer Control (SBC) (B-QSIG-SBC) (December 1999)	EN 301 776
ECMA-299	Private Integrated Services Network (PISN) - Specification, Functional Model and Information Flows - Single Step Call Transfer Supplementary Service (SSCT-SD), 2 nd edition (December 2001)	ISO/IEC 19459 EN 301 918

ECMA-300	Private Integrated Services Network (PISN) - Inter-Exchange Signalling Protocol - Single Step Call Transfer Supplementary Service (QSIG-SSCT), 2 nd edition (December 2001)	ISO/IEC 19460 EN 301 919
ECMA-301	Private Integrated Services Network (PISN) - Specification, Functional Model and Information Flows - Wireless Terminal Location Registration Supplementary Service and Wireless Terminal Information Exchange Additional Network Feature (WTMLR-SD) (June 2000)	ISO/IEC 15428 EN 301 824
ECMA-302	Private Integrated Services Network (PISN) - Inter-Exchange Signalling Protocol - Wireless Terminal Location Registration Supplementary Service and Wireless Terminal Information Exchange Additional Network Feature (QSIG-WTMLR), 2 nd edition (December 2001)	ISO/IEC 15429 EN 301 825
ECMA-303	Private Integrated Services Network (PISN) - Specification, Functional Model and Information Flows - Wireless Terminal Call Handling Additional Network Features (WTMCH-SD) (June 2000)	ISO/IEC 15430 EN 301 826
ECMA-304	Private Integrated Services Network (PISN) - Inter-Exchange Signalling Protocol - Wireless Terminal Call Handling Additional Network Features (QSIG-WTMCH), 2 nd edition (December 2001)	ISO/IEC 15431 EN 301 827
ECMA-305	Private Integrated Services Network (PISN) - Specification, Functional Model and Information Flows - Wireless Terminal Authentication Supplementary Services (WTMAU-SD) (June 2000)	ISO/IEC 15432 EN 301 828
ECMA-306	Private Integrated Services Network (PISN) - Inter-Exchange Signalling Protocol - Wireless Terminal Authentication Supplementary Services (QSIG-WTMAU), 2 nd edition (December 2001)	ISO/IEC 15433 EN 301 829
ECMA-307	Corporate Telecommunication Networks - Signalling Interworking between QSIG and H.323 - Generic Functional Protocol for the Support of Supplementary Services (June 2000)	ISO/IEC 21409 TS 101 905
ECMA-308	Corporate Telecommunication Networks - Signalling Interworking between QSIG and H.323 - Call Transfer Supplementary Services, 2 nd edition (June 2001)	ISO/IEC 21410 TS 101 907
ECMA-309	Corporate Telecommunication Networks - Signalling Interworking between QSIG and H.323 - Call Diversion Supplementary Services, 2 nd edition (June 2001)	ISO/IEC 21411 TS 101 906
ECMA-310	Private Integrated Services Network (PISN) - Specification, Functional Model and Information Flows - Simple Dialog Supplementary Service (SDSD) (June 2000)	ISO/IEC 21407 EN 301 920
ECMA-311	Private Integrated Services Network (PISN) - Inter-Exchange Signalling Protocol - Simple Dialog Supplementary Service (QSIG-SD), 2 nd edition (December 2001)	ISO/IEC 21408 EN 301 921
ECMA-312	Private Integrated Services Network (in PISN) - Profile Standard for the Use of PSS1 (QSIG) Air Traffic Services Networks, 3 rd edition (June 2003)	EN 301 846
ECMA-313	Private Integrated Services Network (PISN) - Specification, Functional Model and Information Flows - Call Identification and Call Linkage Additional Network Feature (CIDLSD) (September 2000)	ISO/IEC 21888 EN 301 922
ECMA-314	Private Integrated Services Network (PISN) - Inter-Exchange Signalling Protocol - Call Identification and Call Linkage Additional Network Feature (QSIG-CIDL), 2 nd edition (December 2001)	ISO/IEC 21889 EN 301 923

ECMA-315	12,65 mm Wide Magnetic Tape Cassette for Information Interchange - Helical Scan Recording - DTF-2 (December 2000)	ISO/IEC 20061
ECMA-316	8 mm Wide Magnetic Tape Cartridge for Information Interchange - Helical Scan Recording - VXA-1 Format, 2 nd edition (December 2001)	ISO/IEC 20062
ECMA-317	Data Interchange on 300 mm Optical Disk Cartridges of Type WORM (Write Once Read Many) using Irreversible Effects - Capacity: 30 Gbytes per Cartridge (December 2000)	ISO/IEC 20162
ECMA-318	Private Integrated Services Network (PISN) - Use of QSIG at the C Reference Point between a PINX and an Interconnecting Network (December 2000)	ISO/IEC 20161 TS 101 914
ECMA-319	Data Interchange on 12,7 mm - 384-Track Magnetic Tape Cartridges - Ultrium-1 Format (June 2001)	ISO/IEC 22050
ECMA-320	Data Interchange on 12,7 mm - 448-Track Magnetic Tape Cartridges - SDLT1 Format (June 2001)	ISO/IEC 22051
ECMA-321	Streaming Lossless Data Compression Algorithm - (SLDC) (June 2001)	ISO/IEC 22091
ECMA-322	Data Interchange on 130 mm Magneto-Optical Disk Cartridges - Capacity: 9,1 Gbytes per Cartridge (June 2001)	ISO/IEC 22092
ECMA-323	XML Protocol for Computer Supported Telecommunications Applications (CSTA) Phase III, 6 th edition (December 2011)	ISO/IEC 18056 TS 102 174
ECMA-324	Private Integrated Services Network (PISN) - Specification, Functional Model and Information Flows - Short Message Service (SMSSD) (June 2001)	ISO/IEC 21989 TS 101 990
ECMA-325	Private Integrated Services Network (PISN) - Inter-Exchange Signalling Protocol - Short Message Service (QSIG-SMS) (June 2001)	ISO/IEC 21990 TS 101 991
ECMA-326	Corporate Telecommunication Networks - Signalling Interworking between QSIG and H.323 - Call Completion Supplementary Services (June 2001)	ISO/IEC 21991 TS 101 989
ECMA-328	Determination of Chemical Emission Rates from Electronic Equipment, 10 th edition (December 2020)	ISO/IEC 28360-1/-2
ECMA-329	8 mm Wide Magnetic Tape Cartridge for Information Interchange - Helical Scan Recording - AIT-3 Format (December 2001)	ISO/IEC 23651
ECMA-330	120 mm (4,7 Gbytes per side) and 80 mm (1,46 Gbytes per side) DVD Rewritable Disk (DVD-RAM), 3 rd edition (June 2005)	ISO/IEC 17592
ECMA-331	Cases for 120 mm and 80 mm DVD-RAM Disks, 2 nd edition (June 2004)	ISO/IEC 17594
ECMA-332	Corporate Telecommunication Networks - Signalling Interworking between QSIG and H.323 - Basic Services (December 2001)	ISO/IEC 23289 TS 102 036
ECMA-333	Private Integrated Services Network (PISN) - Mapping Functions for the Tunnelling of QSIG through H.323 Networks, 2 nd edition (December 2003)	ISO/IEC 23290 TS 102 037
ECMA-334	C# Language Specification, 7 th edition (December 2023)	ISO/IEC 23270
ECMA-335	Common Language Infrastructure (CLI), 6 th edition (June 2012)	ISO/IEC 23271

ECMA-336	Private Integrated Services Network (PISN) - Mapping Functions for the Tunnelling of QSIG through IP Networks (Mapping/IP-QSIG) (June 2002)	ISO/IEC 21992 TS 102 075
ECMA-337	Data Interchange on 120 mm and 80 mm Optical Disk using +RW Format - Capacity: 4,7 and 1,46 Gbytes per Side (Recording speed up to 4X), 4 th edition (June 2008)	ISO/IEC 17341
ECMA-338	80 mm (1,46 Gbytes per side) and 120 mm (4,70 Gbytes per side) DVD Re-recordable Disk (DVD-RW) (December 2002)	ISO/IEC 17342
ECMA-339	Corporate Telecommunication Networks - Signalling Interworking between QSIG and SIP - Basic Services, 2 nd edition (December 2006)	ISO/IEC 17343 TS 102 166
ECMA-340	Near Field Communication Interface and Protocol 1 (NFCIP-1), 4 th edition (June 2024)	ISO/IEC 18092 TS 102 190
ECMA-341	Environmental Design Considerations for ICT & CE Products, 4 th edition (December 2010)	
ECMA-342	RapidIO™ Interconnect Specification (February 2003)	ISO/IEC 18372
ECMA-343	Private Integrated Services Network (PISN) - Specification, Functional Model and Information Flows - Make Call Request Supplementary Service (MCRSD) (June 2003)	ISO/IEC 20113 TS 102 256
ECMA-344	Private Integrated Services Network (PISN) - Inter-Exchange Signalling Protocol - Make Call Request Supplementary Service (QSIG-MCR) (June 2003)	ISO/IEC 20114 TS 102 257
ECMA-345	Private Integrated Services Network (PISN) - Use of QSIG for Message Centre Access (MCA) Profile Standard (June 2003)	ISO/IEC 20115 TS 102 253
ECMA-346	Private Integrated Services Network (PISN) - Specification, Functional Model and Information Flows - Message Centre Monitoring and Mailbox Identification Supplementary Services (MCM-SD / MID-SD) (June 2003)	ISO/IEC 20116 TS 102 254
ECMA-347	Private Integrated Services Network (PISN) - Inter-Exchange Signalling Protocol - Message Centre Monitoring and Mailbox Identification Supplementary Services (QSIG-MCM / QSIG-MID) (June 2003)	ISO/IEC 20117 TS 102 255
ECMA-348	Web Services Description Language (WSDL) for CSTA Phase III, 5 th edition (June 2012)	ISO/IEC 18450
ECMA-349	Data Interchange on 120 mm and 80 mm Optical Disk using +R Format - Capacity: 4,7 and 1,46 Gbytes per Side (Recording speed up to 16X), 4 th edition (June 2008)	ISO/IEC 17344
ECMA-350	Data Interchange on 130 mm Rewritable and Write Once Read Many Ultra Density Optical (UDO) Disk Cartridges - Capacity: 30 Gbytes per Cartridge - First Generation, 3 rd edition (December 2006)	ISO/IEC 17345
ECMA-351	Data Interchange on 90 mm Optical Disk Cartridges - Capacity: 1,3 Gbytes per Cartridge (December 2003)	ISO/IEC 17346
ECMA-352	Near Field Communication interface and protocol -2 (NFCIP-2), 4 th edition (December 2021)	ISO/IEC 21481 TS 102 312
ECMA-353	Data Interchange on 90 mm Optical Disk Cartridges - Capacity: 2,3 Gbytes per Cartridge (June 2004)	ISO/IEC 22533
ECMA-354	Application Session Services (June 2004)	ISO/IEC 22534 TS 102 344

ECMA-355	Corporate Telecommunication Networks - Tunnelling of QSIG over SIP, 3 rd edition (June 2008)	ISO/IEC 22535 TS 102 345
ECMA-356	NFCIP-1 - RF Interface Test Methods, 2 nd edition (June 2013)	ISO/IEC 22536 TS 102 346
ECMA-358	ICT Product Radiated Emissions: 1–6 GHz (December 2004)	
ECMA-359	80 mm (1,46 Gbytes per side) and 120 mm (4,70 Gbytes per side) DVD Recordable Disk (DVD-R) (December 2004)	ISO/IEC 23912
ECMA-360	Corporate Telecommunication Networks - Signalling Interworking between QSIG and SIP - Call Diversion (December 2004)	ISO/IEC 23915 TS 102 393
ECMA-361	Corporate Telecommunication Networks - Signalling Interworking between QSIG and SIP - Call Transfer (December 2004)	ISO/IEC 23916 TS 102 392
ECMA-362	NFCIP-1 - Protocol Test Methods, 3 rd edition (June 2024)	ISO/IEC 23917 TS 102 394
ECMA-363	Universal 3D File Format, 4 th edition (June 2007)	
ECMA-364	Data interchange on 120 mm and 80 mm Optical Disk using +R DL Format – Capacity: 8,55 and 2,66 Gbytes per Side (Recording speed up to 8X), 3 rd edition (December 2007)	ISO/IEC 25434
ECMA-365	Data Interchange on 60 mm Read-Only ODC - Capacity: 1,8 Gbytes (UMD™) (June 2005)	ISO/IEC 25435
ECMA-366	WS-Session - Web Services for Application Session Services, 3 rd edition (December 2011)	ISO/IEC 25437 TS 102 440
ECMA-367	Eiffel: Analysis, Design and Programming Language, 2 nd edition (June 2006)	ISO/IEC 25436
ECMA-368	High Rate Ultra Wideband PHY and MAC Standard, 3 rd edition (December 2008)	ISO/IEC 26907 TS 102 455
ECMA-369	MAC-PHY Interface for ECMA-368, 3 rd edition (December 2008)	ISO/IEC 26908
ECMA-370	TED -  THE ECO DECLARATION 6 th edition (June 2019), with corrections to Annexes B1 and B2 (December 2019)	
ECMA-371	Data Interchange on 120 mm and 80 mm Optical Disk using +RW HS Format - Capacity: 4,7 and 1,46 Gbytes per Side (Recording speed 8X), 2 nd edition (June 2008)	ISO/IEC 26925
ECMA-372	C++/CLI (December 2005)	
ECMA-373	Near Field Communication Wired Interface (NFC-WI), 2 nd edition (June 2012)	ISO/IEC 28361
ECMA-374	Data Interchange on 120 mm and 80 mm Optical Disk using +RW DL Format – Capacity: 8,55 and 2,66 Gbytes per Side (Recording speed 2,4X), 2 nd edition (June 2008)	ISO/IEC 29642
ECMA-375	Case for 120 mm HVD-ROM disk (December 2006)	
ECMA-376	Office Open XML file formats, 5 th edition (December 2021)	ISO/IEC 29500

ECMA-377	Information Interchange on Holographic Versatile Disc (HVD) Recordable Cartridges – Capacity: 200 Gbytes per Cartridge (May 2007)	
ECMA-378	Information Interchange on Read-Only Memory Holographic Versatile Disc (HVD-ROM) – Capacity: 100 Gbytes per disk (May 2007)	
ECMA-379	Test Method for the Estimation of the Archival Lifetime of Optical Media, 3 rd edition (June 2010)	ISO/IEC 10995
ECMA-380	Data Interchange on 130 mm Rewritable and Write Once Read Many Ultra Density Optical (UDO) Disk Cartridges – Capacity: 60 Gbytes per Cartridge – Second Generation (December 2007)	ISO/IEC 11976
ECMA-381	Procedure for the Registration of Assigned Numbers for ECMA-368 and ECMA-369 (December 2007)	ISO/IEC 13560
ECMA-382	120 mm (8,54 Gbytes per side) and 80 mm (2,66 Gbytes per side) DVD Recordable Disk for Dual Layer (DVD-R for DL), 2 nd edition (June 2010)	ISO/IEC 12862
ECMA-383	Measuring the Energy Consumption of Personal Computing Products, 3 rd edition (December 2010)	
ECMA-384	120 mm (8,54 Gbytes per side) and 80 mm (2,66 Gbytes per side) DVD Re-recordable Disk for Dual Layer (DVD-RW for DL) (December 2008)	ISO/IEC 13170
ECMA-385	NFC-SEC: NFCIP-1 Security Services and Protocol, 4 th edition (June 2015)	ISO/IEC 13157-1
ECMA-386	NFC-SEC-01: NFC-SEC Cryptography Standard using ECDH and AES, 3 rd edition (June 2015)	ISO/IEC 13157-2
ECMA-387	High Rate 60 GHz PHY, MAC and PALS, 2 nd edition (December 2010)	ISO/IEC 13156
ECMA-388	Open XML Paper Specification (June 2009)	
ECMA-389	Procedure for the Registration of Categories for ECMA-383, 2 nd edition (December 2009)	
ECMA-390	Front-End Configuration Command for NFC-WI (NFC-FEC), 2 nd edition (June 2012)	ISO/IEC 16353
ECMA-391	Memory-Spot Interface and Protocol (MSIP-1) (December 2009)	
ECMA-392	MAC and PHY for Operation in TV White Space, 2 nd edition (June 2012)	ISO/IEC 16504
ECMA-393	ProxZzzy® for sleeping hosts, 2 nd edition (June 2012)	ISO/IEC 16317
ECMA-394	Recordable Compact Disc Systems CD-R Multi-Speed (December 2010)	
ECMA-395	Recordable Compact Disc Systems CD-RW Ultra-Speed (December 2010)	
ECMA-396	Test Method for the Estimation of Lifetime of Optical Media for Long-term Data Storage, 4 th edition (June 2017)	ISO/IEC 16963
ECMA-397	Short Distance Visible Light Communication (SDVLC) (December 2010)	ISO/IEC 17417
ECMA-398	Close Proximity Electric Induction Wireless Communications (June 2011)	ISO/IEC 17568
ECMA-399	Procedure for the Registration of Assigned Numbers for ECMA-398 (June 2011)	
ECMA-400	Smart Data Centre Resource Monitoring and Control, 3 rd edition (June 2015)	ISO/IEC 19395
ECMA-401	Close Capacitive Coupling Communication Physical Layer (CCCC PHY), 2 nd edition (December 2021)	ISO/IEC 17982

ECMA-402	ECMAScript® 2024 Internationalization API Specification, 11 th edition (June 2024)	
ECMA-403	NFCIP-2 Test Methods (June 2013)	ISO/IEC 19369
ECMA-404	The JSON Data Interchange Syntax, 2 nd edition (December 2017)	ISO/IEC 21778
ECMA-405	Data Interchange on Parallel Write/Read Disk Format for 5 Optical Disks (December 2013)	
ECMA-406	Disk Cassette for 5 Disks with 120 mm Diameter (December 2013)	
ECMA-407	Scalable Sparse Spatial Sound System (S5) – Base S5 Coding (June 2014)	
ECMA-408	Dart Programming Language Specification, 4 th edition (December 2015)	
ECMA-409	NFC-SEC-02: NFC-SEC Cryptography Standard using ECDH-256 and AES-GCM, 2 nd edition (June 2015)	ISO/IEC 13157-3
ECMA-410	NFC-SEC-03: NFC-SEC Entity Authentication and Key Agreement using Asymmetric Cryptography, 3 rd edition (June 2017)	ISO/IEC 13157-4
ECMA-411	NFC-SEC-04: NFC-SEC Entity Authentication and Key Agreement using Symmetric Cryptography, 3 rd edition (June 2017)	ISO/IEC 13157-5
ECMA-412	Framework for distributed real-time Access systems, 3 rd edition (June 2019)	ISO/IEC 20933
ECMA-413	Data Migration Method for BD Recordable and BD Rewritable Disks, 4 th edition (June 2022)	
ECMA-414	ECMAScript® Specification Suite, 3 rd edition (December 2017)	ISO/IEC 22275
ECMA-415	NFC-SEC Test Methods (December 2016)	ISO/IEC 22425
ECMA-416	Scalable Sparse Spatial Sound System (S5) – Base S5 Coding in Frequency Domain (June 2018)	
ECMA-417	Architecture for a distributed real-time Access system 3 rd edition (August 2021)	ISO/IEC 24643
ECMA-418	Psychoacoustic metrics for ITT equipment, 3 rd edition (December 2024)	
ECMA-419	ECMAScript® embedded systems API specification, 2 nd edition (June 2023)	
ECMA-420	Device interface information for high-speed collation using holographic optical correlation, 3 rd edition (December 2024)	
ECMA-421	Quality discrimination method for optical disks and operating method of storage systems for long-term data preservation, 2 nd edition (June 2024)	
ECMA-422	C# Specification Suite (December 2022)	ISO/IEC 20619
ECMA-423	Holographic Data Storage Disk (HDSD) – Capacity: 1 Tbyte per disk (June 2023)	
ECMA-424	CycloneDX Bill of materials specification (June 2024)	
ECMA-425	Statistical background correction for information technology and telecommunications equipment noise measurements (December 2024)	
ECMA-426	Source map format specification (December 2024)	

Technical Reports in force (electronically available [here](#))

ECMA TR/18	The Meaning of Conformance to Standards (September 1983)	
ECMA TR/27	Method for the Prediction of Installation Noise Levels, 2 nd edition (June 1995)	
ECMA TR/36	Guidelines on Additional Parameters Recommended for Procurement Specifications for 12,7 mm Magnetic Tapes (December 1986)	
ECMA TR/46	Security in Open Systems - A Security Framework (July 1988)	
ECMA TR/53	Handling of Bi-directional Texts, 2 nd edition (June 1992)	
ECMA TR/55	Reference Model for Frameworks of Software Engineering Environments, 3 rd edition (June 1993)	
ECMA TR/57	Private Integrated Services Networks, 2 nd edition (June 1999)	ETSI EG 201 463
ECMA TR/58	Databases and Networking (June 1992)	
ECMA TR/59	Object-Oriented Databases (June 1992)	
ECMA TR/61	User Interface Taxonomy (June 1992)	
ECMA TR/62	Product Noise Emission of Computer Business Equipment (June 1993)	
ECMA TR/64	Secure Information Processing versus the Context of Product Evaluation (December 1993)	
ECMA TR/66	Mapping of PCTE to the ECMA/NIST Frameworks Reference Model (June 1994)	
ECMA TR/67	Compendium of PTN Management Services (December 1994)	ETSI ETR 245
ECMA TR/68	Scenarios for Computer Supported Telecommunications Applications (CSTA) Phase II (December 1994)	
ECMA TR/69	Reference Model for Project Support Environments (December 1994)	
ECMA TR/70	Ecma Product-related Environmental Declaration, 3 rd edition (June 2004)	
ECMA TR/71	DVD Read-Only Disk - File System Specifications (February 1998)	
ECMA TR/72	Glossary of Definitions and Terminology for Computer Supported Telecommunications Applications (CSTA) Phase III, 3 rd edition (June 2000)	ISO/IEC TR 18053
ECMA TR/73	H.323 / B-ISDN Signalling Interoperability (December 1998)	
ECMA TR/74	A Guide to the Application of the EMC Directive to ITE (June 1999)	
ECMA TR/75	Corporate Telecommunication Networks (CN) - Standardization Plan, 2 nd edition (June 2000)	ETSI EG 201 017
ECMA TR/76	Private Integrated Services Network (PISN) - Architecture and Scenarios for Private Integrated Services Networking (December 1999)	ISO/IEC TR 14475
ECMA TR/77	Telephony System with Integrated Internet Access - Overview (December 1999)	
ECMA TR/78	ECMA Protection Profile - E-COFC Public Business Class (December 1999)	

ECMA TR/79	Private Integrated Services Network (PISN) - Wireless Terminal Mobility (WTM) - WTM between networks - Requirements (February 2000)	
ECMA TR/80	Migrating to CSTA Phase III (June 2000)	
ECMA TR/81	Interoperation of PISNs with IP Networks (September 2000)	ISO/IEC TR 21890 ETSI TR 101 913
ECMA TR/82	Scenarios for Computer Supported Telecommunications Applications (CSTA) Phase III, 2 nd edition (June 2009)	
ECMA TR/83	One Standard - One Test, Supplier's Declaration of Conformity (11SDoC) - Scorecard objectives and concept (June 2001)	
ECMA TR/84	Common Language Infrastructure (CLI) - Information Derived from Partition IV XML File, 6 th edition (June 2012)	ISO/IEC TR 23272
ECMA TR/85	Using ECMA-323 (CSTA XML) in a Voice Browser Environment (December 2002)	ISO/IEC TR 18057 ETSI TR 102 171
ECMA TR/86	Corporate Telecommunication Networks - User Identification in a SIP/QSIG Environment (December 2003)	ETSI EG 202 303
ECMA TR/87	Using CSTA for SIP Phone User Agents (uaCSTA) (June 2004)	ISO/IEC TR 22767 ETSI TR 102 348
ECMA TR/88	Designing an Object Model for ECMA-269 (CSTA) (June 2004)	
ECMA TR/90	Session Management, Event Notification, and Computing Function Services - Amendments for ECMA-348 (December 2005)	
ECMA TR/91	Enterprise communication in next generation corporate networks (NGCN) involving public next generation networks (NGN) (December 2005)	ISO/IEC TR 26905 ETSI TR 102 478
ECMA TR/92	Corporate Telecommunication Networks – Mobility for Enterprise Communications, 2 nd edition (December 2010)	ISO/IEC TR 26927 ETSI TR 102 477
ECMA TR/93	Measuring Emissions from Modules (December 2007)	
ECMA TR/94	Assessment of the Human Exposure to Electromagnetic Fields for Low Power Electronic and Electrical Apparatus according to EN 50371:2002 (December 2007)	
ECMA TR/95	Next Generation Corporate Networks (NGCN) - General (June 2008)	ISO/IEC TR 12860 ETSI TR 102 633
ECMA TR/96	Next Generation Corporate Networks (NGCN) - Identification and Routing (June 2008)	ISO/IEC TR 12861 ETSI TR 102 634
ECMA TR/97	Guide for Assessment of Human Exposure to Electromagnetic Fields from Multimedia Products in accordance with IEC/EN 62311 (June 2009)	
ECMA TR/98	JPEG File Interchange Format (JFIF) (June 2009)	
ECMA TR/99	Constant Sound Power Fan Curves for Small Air-moving Devices, 2 nd edition (December 2010)	
ECMA TR/100	Next Generation Corporate Networks (NGCN) - Security of Session-based Communications (December 2009)	ISO/IEC TR 16166

ECMA TR/101	Next Generation Corporate Networks (NGCN) - Emergency Calls, 2 nd edition (December 2010)	ISO/IEC TR 16167
ECMA TR/102	Personal Networks – Overview and Standardization Needs (December 2010)	
ECMA TR/103	Business Trunking - NGCN-NGN Interfaces Implementation Guide (June 2011)	ETSI TR 183 069
ECMA TR/104	ECMAScript® Test Suite, 2nd edition (December 2016)	
ECMA TR/105	A Shaped Noise File Representative of Speech (December 2012)	
ECMA TR/106	Guidance and Comparison between 60950-1 and 62368-1 (February 2013)	
ECMA TR/107	An optional alternate background noise correction sensitive to the steadiness of background noise, 3 rd edition (December 2017)	
ECMA TR/108	Proposal of new parameters, T-TNR and T-PR for total evaluation of multiple tones (June 2019)	
ECMA TR/109	Class specifications for embedded hardware components (June 2021)	
ECMA TR/110	Recommendations and best practices for scripts on connected sensing devices (June 2021)	
ECMA TR/111	Overview of Universal Archive Disk Format (UADF) (December 2022)	
ECMA TR/112	Universal Disk Format (UDF) – Part 1 to 8 (December 2023)	

Ecma By-laws

Art. 1

Constitution and Head Office

1.1

Ecma International - further called Ecma - is an international industry association based in Europe, and has been constituted according to these By-laws and Articles 60 et seq. of the Swiss Civil Code.

1.2

The Headquarters of the Association is in Geneva.

Art. 2

Purpose

2.1

The purpose of the Association is to develop, in co-operation with the appropriate national, European and international organizations as a scientific endeavour and in the general interest standards and technical reports in the fields of information and communications technologies and to publish them free of charge.

2.2

The Association shall be a non-profit-making organization and shall devote itself to no commercial activity whatsoever.

Art. 3

Membership

3.1

The Association shall consist of the following classes of Ecma members:

- a) Companies
 - ordinary members
 - associate members
 - Small and Medium sized Enterprises members (SME)
 - Small Private Companies members (SPC)
- b) Not-For-Profit organizations members (NFP)

Any other class of members shall be determined by the General Assembly with a two thirds majority of all ordinary members.

3.2

- a) For non-SPC members:

A proposed company member shall not be accepted if it holds at least 50 per cent of the capital of an existing company member nor if at least 50 per cent of its capital is held by an existing company member.

- b) For SPC members:

A proposed SPC member shall not be accepted if it holds at least 50 per cent of the capital of an existing company member nor if at least 35 per cent of its capital is held by an existing company member.

3.3

- a) For non-SPC members:

No two or more companies where at least 50 per cent of whose capital is held by the same company, which is not a company member itself, may be company members but shall be represented by one of these companies only.

- b) For SPC members:

No two or more SPCs where at least 35 per cent of whose capital is held by the same company, which is not a company member itself, may be SPC members but shall be represented by one of these SPCs only.

3.4

Additional classes of Ecma members established according to Article 3.1 shall have such qualifications and be entitled to such rights and privileges and have such obligations as shall be determined by the General Assembly with a two thirds majority of all the ordinary members.

3.5

Companies shall be admitted to any class of company membership in accordance with Art. 4.

3.6

Membership fees for all classes of company membership are decided by the General Assembly with a two thirds majority of all ordinary members.

3.7

Ecma membership shall be terminated in the cases set out in Art. 5.

3.8 Ordinary members

3.8.1

Ordinary membership may be applied for by a company which has interest and experience in matters related to one or more Technical Committees of the Association, and which wishes to exert the right to vote at the General Assembly and to exert other exclusive rights defined in the By-laws and Rules, such as serving on the Executive Committee and as Chair of a Technical Committee.

3.8.2

The principal representative of each ordinary member, or in the principal representative's absence, its alternate representative, will have one vote in the General Assembly.

Voting rights may be exerted with effect from the first full month upon admission as Ecma member.

3.9 Associate members

3.9.1

Associate membership may be applied for by a company which has interest and experience in matters related to one or more Technical Committees of the Association but without the right to vote in the General Assembly.

3.9.2

An associate member is fully entitled to participate in the work of Technical Committees and obtain all relevant papers.

3.9.3

Representatives of the associate members shall have the right to take part in the discussions of the General Assembly.

3.10 SME members

3.10.1

SME membership may be applied for by a company the annual turnover of which is less than Swiss Francs 100'000'000. -.

3.10.2

The rights of SME members are identical with those of associate members as specified in Art. 3.9.

3.11 SPC members

3.11.1

SPC membership may be applied for by an organization - a company or other legal for-profit organization - with no more than 25 employees and a global annual turnover of less than Swiss Francs 10'000'000.-.

3.11.2

The rights of SPC members are identical with those of associate members as specified in Art. 3.9, with the exception that an SPC member is only entitled to participate in one TC.

3.12 NFP members

3.12.1

Annual NFP membership may be applied for by a non-profit-making organization. Further yearly extensions of an NFP membership are possible, via application to the Secretary General by November of each year for the following year.

3.12.2

An NFP member is entitled to participate in the work of Technical Committees and may observe the discussion at the General Assembly.

Art. 4

Acceptance of a new Ecma member

4.1

Application for membership and membership class shall be made to the Secretary General in a written notice carrying an authorized signature.

The application shall specify that the applicant has received the By-laws, the Rules, the Code of Conduct in patent matters and other Ecma IPR policies, and declare that it adheres to them without restriction.

4.2

Decisions on acceptance shall be made by the General Assembly with a two thirds majority of all the ordinary members. The accepted applicant shall indicate the Technical Committees in which they intend to participate.

Art. 5

Termination of Ecma membership

5.1

a) Membership of a company shall be terminated in the following cases:

- Withdrawal by the company member:

Withdrawal by a company can only occur at the end of a calendar year and requires a written three-month notice carrying an authorized signature to the Secretary General (to be received by the Ecma Secretariat before 1 October).

- The company ceasing to exist.
- The conditions for membership set forth in Articles 3.2 and 3.3 of the present By-laws no longer being complied with.
- By expulsion for violation of By-laws and Rules or for any other conduct prejudicial to the interest and correct functioning of the Association.
- By expulsion after failure to pay the membership fee during the year in which it becomes due. This will happen automatically on 31 December and shall not relieve the member of the obligation to pay such fees that are due or past due according to the terms of the invoice. In justified hardship cases the Ecma management may extend - on a case by case basis - the membership payment deadline.

b) Membership of an NFP shall be terminated in the following cases:

- At the end of the year, unless extension of NFP membership has been granted by the Ecma GA.
- Withdrawal upon written notice to the Secretary General, to take effect upon receipt.
- The NFP ceasing to exist.
- By expulsion for violation of By-laws and Rules or for any other conduct prejudicial to the interest and correct functioning of the Association.

5.2

No company member may be expelled for failure to adhere to one or several agreed standards.

5.3

Any proposal to expel an Ecma member shall be backed by at least one-fifth of all the ordinary members. The proposal to expel shall be on the agenda for the General Assembly at which it is to be discussed so as to give the member the opportunity to present its case.

5.4

A two-thirds majority of all the ordinary members is necessary to expel an Ecma member. Such expulsion will become effective 15 days after notification by registered mail.

5.5

An Ecma member which has been expelled can only be re-admitted by the General Assembly with a two-thirds majority of all ordinary members.

Art. 6

Change of class of company membership

6.1

If a company member wishes to change its membership class they shall apply for one of the other classes of membership according to the conditions set out in these By-laws.

6.2

An application for a change to a higher class of membership (more rights, higher fee) shall be made in a written notice carrying an authorized signature to the Secretary General and it shall be noted by the General Assembly. When changing to the Ordinary member class, voting rights may be exerted immediately after the membership class change was noted by the General Assembly.

6.3

An application for a change to a lower class of membership (less rights, lower fee) shall be made in a written notice carrying an authorized signature to the Secretary General before 1 October and it shall be noted by the GA. When changing from the Ordinary member class, voting rights may continue to be exerted until the end of the calendar year.

6.4

If a company member does not fulfil the conditions of its current membership class due to modifications of the By-laws the company member is not obliged to change its current class of membership. However, the conditions of the modified By-laws shall apply.

Art. 7

Structure

7.1

The Association shall consist of:

The General Assembly.

The Management.

The Executive Committee.

7.2

The General Assembly shall consist of the ordinary members and shall be the highest authority of the Association. It shall control the Association and appoint and control its Management.

7.3

The Management shall consist of a President, a Vice-President and a Treasurer.

The Management shall not be personally liable for the debts, liabilities or other obligations of the Association.

7.4

The President and the Vice-President shall be individuals elected for one year by the ordinary members at a General Assembly.

After a call for nominations by the Secretary General, the Executive Committee and all Ecma members may nominate candidates for election no later than 45 days before the General Assembly. Only representatives of ordinary members can be nominated. Candidates should have previously served on the Executive Committee for a reasonable amount of time.

The Secretary General shall post the names of nominees no later than 30 days before the General Assembly.

The President and the Vice-President can be re-elected any number of times provided that neither serves more than three consecutive years.

7.5

The President shall, through the President's signature, commit the Association in any business or transaction directly connected with the purpose of the Association.

7.6

In the absence of the President, the Vice President shall perform all the duties of the President, and when so acting shall have all the powers of the President.

If either the President or Vice-President roles are vacated through resignation, death, incapacity, or expulsion, the role remains vacant until the next election. If both the President and Vice-President roles are vacated concurrently, the Secretary General shall perform the duties of the President until these roles get filled at the next General Assembly election.

7.7

There shall be a Treasurer whose duty shall be determined by the General Assembly. The Rules set out in 7.4 shall apply to the Treasurer's office, except that there shall be no limit in the number of consecutive years in office.

7.8

The Executive Committee makes recommendations to the General Assembly regarding business, legal and managerial matters and regarding the formation, activities, reorganization or dissolution of Technical Committees. The Executive Committee shall be composed of the three members of the Ecma Management, a maximum of eight members elected from representatives of ordinary members, and a maximum of four members elected from representatives of the remaining Ecma membership.

The members and the Chair of the Executive Committee shall be individuals elected by simple majority for one year at a General Assembly by the ordinary members.

After a call for nominations by the Secretary General, the Ecma Management and all Ecma members may nominate candidates for election no later than 45 days before the General Assembly. The Secretary General shall post the names of nominees no later than 30 days before the General Assembly.

The Chair shall be eligible for re-election, subject to a maximum term of office of three consecutive years. The other members can be re-elected any number of times. Only one representative per Ecma member can be elected.

7.9

Candidates for the four remaining Ecma membership positions shall be representatives of an associate, SME, SPC or NFP member. Those candidates may be nominated after a call for nomination by the Secretary General as specified in 7.8. In the case where there are more than four individuals nominated, the four candidates receiving the highest number of votes shall be elected.

Art. 8

General Assembly

8.1

The President shall each year call at least two ordinary General Assemblies. Notice of the time and place of the General Assembly shall be given at least thirty days before the date of the General Assembly. The agenda and supporting documents for the General Assembly shall be made available at least fifteen days before the General Assembly.

8.2

Special General Assemblies for any purpose or purposes unless otherwise prescribed by these By-laws or the Rules of the Association may be called by the President, and shall be called by the President at the request in writing of at least one-fifth of all the ordinary members. Such request shall state the purpose or purposes of the proposed General Assembly.

Notice of Special General Assemblies stating the time, place and object thereof, shall be given to each ordinary member at least three weeks before the date of the General Assembly and shall include the agenda and supporting documents for the General Assembly.

The business transacted at any Special General Assembly shall be limited to the purposes stated in the notice.

8.3

Unless otherwise restricted by these By-laws or the Rules of the Association, any action required or permitted to be taken at a General Assembly may be taken without a meeting by a postal ballot (including through emails or any other suitable electronic means), if it has been announced in advance and has been approved by the General Assembly.

8.4

The General Assemblies may take place under the form of a physical meeting, or exclusively by electronic means, without a physical meeting place (virtual meeting), or with a physical venue and a virtual meeting at the same time (hybrid meeting).

For due conduct of virtual or hybrid meetings, the following conditions shall be met:

1. The meeting platform is available to the participants and operational;
2. The identity of the participants is clearly established;
3. The oral contributions of each participant are directly transmitted;
4. Each participant can participate in the debate;
5. Technical or procedural means are used to ensure that the votes of the ordinary members cannot be falsified.

Ecma does not have to provide for the independent voting representative that is required by Article 701d of the Swiss Code of Obligations in the case of a virtual meeting.

8.5

A majority of all the ordinary members shall be present or represented by proxy at any General Assembly, or respond to a postal ballot, in order to constitute a quorum for transaction of the business except as otherwise provided by these By-laws or the Rules of the Association.

8.6

Unless otherwise prescribed by these By-laws or the Rules of the Association, the vote of the majority of all the ordinary members shall decide any question.

Art. 9

Publication of Standards and Technical Reports

9.1

The adoption of such documents for publication by the Association shall require approval by at least two thirds of all the ordinary members.

9.2

Proposed drafts shall be made available by the Secretary General at least two months in advance of the date at which they will be voted upon.

9.3

It is not mandatory for Ecma members to implement any Ecma standard.

9.4

All documents when approved shall be made available to all interested parties without restriction.

9.5

A Corrigendum contains corrections to an already published document and is published as a separate document that contains only corrections. A Corrigendum may be prepared and approved by a TC when a Standard or a Technical Report contains errors which makes it unusable as published. A Corrigendum shall be approved by the Technical Committee members either at a meeting or by a postal ballot of a minimum of three weeks. The Executive Committee shall be informed before the commencement of the approval procedure. The Corrigendum shall be incorporated in a revision of the Standard or Technical Report.

Art. 10**Ad Hoc Committees****10.1**

The General Assembly may delegate authority for specific purposes to ad hoc committees.

10.2

Unless otherwise decided at the time of its appointment each ad hoc committee may co-opt additional members should it so desire.

10.3

No ad hoc committee may meet for more than one year without being reappointed.

Art. 11**Secretariat****11.1**

There shall be a permanent Secretariat of the Association responsible to the General Assembly.

11.2

A Secretary General shall be appointed by the General Assembly and shall be responsible for the operation of the Secretariat.

Art. 12**Technical Committees****12.1**

Technical Committees (TCs) will be formed by the Secretary General when so decided at a General Assembly.

12.2

Any Ecma member may participate in any TC.

Art. 13**Fiscal year**

The fiscal year shall commence on 1 January and end on 31 December.

Art. 14**Finance****14.1**

The annual budget of the Association shall be approved by at least two thirds of the ordinary members represented at an ordinary General Assembly.

14.2

The Association shall be financed by its company members. The fees for each membership class are set in advance by the ordinary members during an ordinary General Assembly and are based on the budget for the following fiscal year. Such fees shall be used to finance the activity of the Association and its administrative expenses. Any surplus of income over the expenses shall be carried over to the next budget.

14.3

The Secretary General shall be responsible for expenditures within the budget.

14.4

The Management may authorize expenditures outside the budget to an amount not exceeding 10 per cent of the corresponding item in the current year budget. Any expense above this shall be approved by the majority of all ordinary members.

Art. 15**Dissolution**

In the event of the dissolution of the Association, its assets are first used to discharge its liabilities. Any balance of liability shall be borne by the company members in proportion to their annual fees. Any surplus funds remaining after the liabilities have been discharged will be distributed to those which are company members at the date of dissolution in proportion to their total contributions to the Association.

Art. 16**Amendments****16.1**

The By-laws and any Rules that may be adopted by the General Assembly, including any policies on intellectual property rights (including the Code of Conduct in patent matters), can only be modified at an ordinary or special General Assembly. The proposed amendments shall be presented with the rationales for the change enclosed with the agenda and notified to the company members according to the provisions of Articles 8.1 and 8.2.

16.2

Amendments shall require approval by two thirds of all the ordinary members.

Art. 17

Litigation

Any dispute arising during the life of the Association or during its dissolution either between the members of the Association and its Management or between the members and the Association or between the members themselves as a consequence of the Association's activity shall be decided upon by the Courts of the Canton of Geneva. Swiss law is applicable in all cases.

Ecma Rules

1.

Language

The English language, as written in the United Kingdom, shall be the official language of the Association.

2.

System of measurement

The metric system of measurement according to ISO 1000 and the International System of Units (SI) according to ISO 31 shall be used.

3.

Representation of company members

Each company member shall appoint one of its officers or executives who shall represent this member in General Assemblies and who shall have full authority to commit the member on all matters listed in the agenda of the General Assembly. Company members shall notify the Association of any changes in their representation. Each company member may appoint one alternate representative.

4.

Communication with the members and use of electronic means

4.1

Communications between Ecma and its members may be made by letter, email or any other suitable electronic means.

4.2

The meetings of the different Ecma committees other than the General Assembly, may be held through electronic means. For due conduct of virtual or hybrid meetings the following criteria shall be met:

1. Access to the meeting platform is available to the participants and operational;
2. The identity of the participants is clearly established;
3. The oral contributions of each participant are directly transmitted;
4. Each participant can participate in the debate;
5. Technical or procedural means are used to ensure that the votes, if any, cannot be falsified.

The participants bear the risk of a technical issue occurring at their own premises, such as hardware or software problems or problems with the internet connection.

4.3

The different Ecma committees other than the General Assembly may also discuss matters and take decisions by circular emails or by any other suitable electronic means, provided that all members of that committee duly take part to the discussions and have sufficient time to express their position before a decision is taken.

4.4

If a technical issue arises during one of these virtual or hybrid meetings with the result that the meeting cannot be duly conducted to its end, the decisions that have been taken before the technical issue remain valid. The remaining part of the meeting and votes, if any, may take place through an exchange of emails or any other suitable electronic means, provided that all participants can sufficiently express their opinion before a decision is taken, and unless a member requires that another meeting is held for the remaining part of the discussions.

5.

General Assemblies

5.1

Representatives may invite additional individuals from their respective member company to participate in an advisory capacity at a General Assembly.

5.2

The ordinary members at a General Assembly may be represented by a proxy. A written proxy shall be established indicating the item or items of the agenda to which it is restricted, and shall be executed by either the Secretary General or an ordinary member. If the member is not present or represented and if this proxy form is not returned to the Secretary General prior to the GA meeting, the proxy is given to the Secretary General. The Secretary General votes by taking the position which, to the Secretary General's assessment, is most favourable to Ecma as an organization.

5.3

The President or in the President's absence the Vice-President shall preside at all General Assemblies. In absence of both, the ordinary members present or represented by proxy shall elect a Chair for that particular meeting.

5.4

In the case of a virtual or hybrid General Assembly meeting, and a loss of remote connection for the President and the Vice-President, the ordinary members present or represented by proxy shall elect a Chair for the remaining part of the meeting.

5.5

In case of a virtual or hybrid General Assembly meeting, the participants bear the risk of a technical issue occurring at the ir own premises, such as hardware and software problems or problems with the internet connection. However, the minimum quorum as required by Article 8.5 of the By-laws shall be fulfilled at any time during the meeting.

5.6

If technical issues occur during a virtual or hybrid General Assembly meeting which impact the meeting from being duly conducted and which cannot be solved within a reasonable time frame, not exceeding a maximum of two hours, a new General Assembly shall be convened for the remaining part.

However, unless there is an opposition from one of the ordinary members, the remaining decisions may also be taken without a meeting by a postal ballot (including through emails or any other suitable electronic means), provided that all participants can sufficiently express their opinion before a decision is taken and provided that the minimum quorum as required by Article 8.5 of the By-laws remains fulfilled.

The decisions taken by the General Assembly meeting before the technical problems occurred remain valid.

6.

Executive Committee

6.1

A Committee consisting of individuals elected by the General Assembly will be set up under the name of Executive Committee (ExeCom), whose terms of reference will be as follows:

6.1.1

To hold a meeting at least twice a year.

6.1.2

To prepare terms of reference for new Technical Committees in accordance with the rules for the formation of a Technical Committee.

6.1.3

To nominate a provisional Chair and Vice-Chair for each new Technical Committee.

6.1.4

To review and co-ordinate the progress of the TCs and, from time to time, review the terms of reference given to Technical Committees. Where required, Chairs of TCs shall attend the meeting.

6.1.5

To make recommendations to the disbandment of Technical Committees.

6.1.6

To provide assistance and advice to the Management on business, legal and managerial matters and any other topic as and when required.

6.1.7

To propose nominations for the election of the Management at the General Assembly.

6.2

The members of the Ecma Management are members of the Executive Committee. Members of the Management may also be entitled to serve as Chair of the Executive Committee as specified in Art. 7.8 of the Ecma by-laws.

7.

Technical Committees

7.1

Formation of Technical Committees (TCs):

7.1.1

TCs will be formed by the Secretary General (SG) when so decided at a General Assembly.

The ExeCom may provisionally authorize the operation of a TC before the approval of the GA.

7.1.2

a) Any proposal for the setting up of a TC shall include the suggested terms of reference, the scope, and be sent to the SG.

b) Any new work item proposal in a TC or TG shall be supported by at least three Ecma members of which there is at most one NFP member.

c) A TC may operate as a Royalty-Free TC (RFTC) if approved by the General Assembly per the Ecma International Royalty-Free patent policy extension option.

7.1.3

The ExeCom shall nominate a provisional Chair and Vice-Chair.

7.1.4

The SG shall then convene the first meeting of the TC.

7.2

Operating procedures - Rules and recommendations for the TCs:

7.2.1

Members of TCs are representatives of Ecma members.

7.2.2

Ecma members are entitled to send one or more representatives to any TC.

7.2.3

Voting on any matter shall be by simple majority of Ecma TC members. Each Ecma member has only one vote.

7.2.4

It is recommended that in the course of its ordinary work the TC should not use voting unless it is impossible to make progress without a vote.

7.2.5

One-time visitors can attend a meeting only at the invitation of the SG at the request of the TC. They have no voting rights.

7.2.6

Individuals can participate in the work of a TC as invited experts. They participate only at the invitation of the SG at the request of the TC. They have no voting rights. Invited experts shall comply with the Ecma policies and sign the appropriate form before participating. The invitation to participate may be withdrawn by the SG at any time.

7.2.7

The provisional Chair and Vice-Chair nominated by the ExeCom shall act for an initial period which shall be not less than six months from the date of the first meeting and which shall include the first three meetings.

7.2.8

At the first meeting of the TC which takes place after the end of the initial period, a Chair and Vice-Chair shall be elected from among the ordinary member representatives. However, when no ordinary member representative is available for such responsibility, the TC may appoint an individual as Chair and / or Vice-Chair among the remaining Ecma members and the GA shall be notified.

7.2.9

The Chair and Vice-Chair, having been elected from among the member company representatives, hold office for a term of 12 months and are eligible for re-election.

7.2.10

Meetings of the TCs shall be conducted by the Chair, according to the By-laws and Rules of Ecma. A representative of the Secretariat shall act as Secretary for all TC meetings. The Vice-Chair or an appointed TC expert should assist the secretary and should act for the secretary if the latter is unable to attend.

7.2.11

Agenda for meetings of the TCs shall be prepared by the Chair and an officer of the Secretariat taking into account suggestions made by members of the TC. The agenda shall be made available to all members three weeks before each meeting; at the opening of the meeting it can be updated and it shall be approved.

7.2.12

The secretary of a TC shall be responsible for the preparation of minutes of the meetings.

7.2.13

The minutes shall be made available by the secretary within three weeks after a meeting to all members of the TC, the General Assembly, and the ExeCom.

7.2.14

The first item on the agenda of each TC shall be the review and approval of the minutes of the preceding meeting. The minutes, after approval, shall constitute the official record of the meeting of a TC.

7.2.15

Any amendment of terms of reference of TCs shall be addressed to the SG for discussion between the TC Chair and the ExeCom. The ExeCom may provisionally authorize such amendment before the approval of the GA.

7.2.16

The Chair is responsible for the preparation of a semi-annual report for each TC: The Chair will be assisted by the Vice-Chair and an officer of the Secretariat in this task and the report will be submitted to the General Assembly. The report will contain a description of the results achieved to date and an outline of the work to be carried out during the next year.

7.2.17

This report will be made available to all members of the TC for approval.

7.2.18

Any member of a TC has the right to ask for a minority report, which they shall provide, to be included into the semi-annual report.

7.2.19

The work of all TCs will be discussed every six months at a meeting of the ExeCom and the SG at which meetings the semi-annual reports will be presented.

7.2.20

First priority in discussion at the meetings of the TCs shall be given to items on the agenda.

7.2.21

Under no circumstances should any technical contribution be decided upon at a TC meeting unless it has been made available to all TC members at least three weeks before the meeting.

7.2.22

Face-to-face meetings may be held in Geneva or at any other place. Economy and efficiency shall be a factor in choosing the meeting place and the meeting mode. Electronic or a combination of electronic and face-to-face meetings are possible options, left to the TC's decision.

8.

Task Groups (TGs)

8.1

A Technical Committee may form TGs for the accomplishment of specific tasks within the scope of the TC. A TG may operate as a Royalty-Free TG (RFTG) if approved by the General Assembly per the Ecma International Royalty-Free patent policy extension option.

8.2

At least two members of the TC shall agree to take an active part in the work of a TG.

8.3

Terms of reference of the TG shall be included in the minutes of the meeting of the TC at which the TG has been formed. In case of a "Royalty-Free TG" the Terms of Reference require the approval of the General Assembly.

8.4

TGs shall report at each meeting to the TC on their activities; these reports shall appear in the minutes of the TC.

8.5

The Convenor of a TG shall be appointed by the TC upon nomination by the TG for 12 months and is eligible for re-appointment.

8.6

Face-to-face meetings may be held in Geneva or at any other place. Economy and efficiency shall be a factor in choosing the meeting place and the meeting mode. Electronic or a combination of electronic and face-to-face meetings are possible options, left to the TG's decision.

9.

Membership and fees

9.1

The General Assembly shall set the annual membership fee for the following fiscal year based on the budget for that year.

Although the Association shall be non-profit making, reserves may be accumulated if so decided by the General Assembly.

For each class of company membership, the annual fee shall be:

Ordinary members: The full nominal fee

Associate members: One half of the full nominal fee

SME members: One quarter of the full nominal fee

SPC members: About five percent of the full nominal fee.

There is no fee for NFP members (Not-For-Profit organizations).

9.2

Annual membership begins on the first day of the fiscal year and continues throughout that year.

Existing members as of the last day of the current fiscal year continue as members of the same class as of the first day of and throughout the following fiscal year, unless a change of the membership category has been approved (see 9.5).

The company membership fee is due within 60 days upon receipt of an invoice.

If the membership fee is not paid within four months upon receipt of the invoice the access right of the member to all Ecma members' privileged resources and its participation in the Ecma standardization work may be automatically suspended without any further notice by Ecma.

9.3

The Secretary General shall indicate at the first ordinary General Assembly of the fiscal year the name(s) of the company member(s) having not paid the annual fee. The General Assembly shall decide on the sanctions to be taken, up to and including temporary suspension of all voting privileges.

9.4

Any withdrawing company member shall pay the full annual fee for the appropriate membership class for the fiscal year at the end of which the withdrawal becomes effective.

9.5

Any new company member admitted at the General Assembly held in the first half of a fiscal year shall pay one half of the full annual fee for its membership class in that fiscal year.

Any new company member admitted at the General Assembly held in the second half of a fiscal year shall not pay a fee for that fiscal year, but shall pay the full annual fee for its membership class in the following fiscal year.

Any upgraded (see By-laws Art.6.2) company member admitted at the General Assembly held in the first half of a fiscal year shall pay one half of the full annual fee for its new membership class for the second half of that fiscal year.

Any upgraded company member admitted at the General Assembly held in the second half of a fiscal year shall not pay an additional fee for its new membership class for that fiscal year, but shall pay the full annual fee for its new membership class in the following fiscal year.

Downgraded membership (see By-laws Art. 6.3) becomes effective at the beginning of the fiscal year following the fiscal year when the downgrading was approved.

9.6

If an NFP is an organization with several organizations as members, then normally it can only become an NFP member in Ecma International if its members do not individually qualify for Ordinary, Associate, SME or SPC membership in Ecma. If a member is itself a membership organization, the rights of membership granted to such member will only extend to the nominated or employee-representatives of such member.

10.

Operating expenses

10.1

Operating expenses of the Association shall consist of salaries, travel and office expenses of the Secretariat and publication costs.

10.2

Expenses of Ecma members including those connected with ad hoc committees, TCs and TGs are not part of the operating expenses of the Association.

10.3

The Secretary General of Ecma is responsible to the Treasurer for the operating expenses of the Association.

10.4

The general accounting of the Secretariat shall be reviewed once a year by an Auditor appointed by the Treasurer and approved by the General Assembly.

10.5

The General Assembly shall discharge from liability the Management and the Secretary General for their activities during the concerned period.

11.

Collaboration and liaison relationships

Ecma may want to collaborate or liaise with other organizations. There should be an agreement that defines the scope of the collaboration. The agreement should at least address:

- contribution of material to and from other organizations
- referencing material of other organizations (informative or normative)
- participation of representatives from other organizations in the work of Ecma and its Technical Committees
- clarification of all policy and procedural matters, such as IPRs (especially patent policy and copyrights, publications)
- possible creation of joint working groups (and their internal rules and procedures regarding the rights and duties of participating entities)

The General Assembly shall approve collaboration and liaison agreements.



Ecma IPR policies

The current Ecma IPR policies can be found on the Ecma website (<https://www.ecma-international.org/policies/by-ipr/>)

- Ecma Code of Conduct in patent matters (based on the RAND policy)
- Royalty-Free patent policy extension option
Related forms:
 - 1) Registration form for the RFTG
 - 2) Withdrawal form from the RF TC or TG
 - 3) Opt-out form for the RF policy
- Ecma text copyright policy
- Ecma policy on submission, inclusion and licensing of software
 - 1) the exhibit A
 - 2) the exhibit B (software submitter contribution form)
 - 3) attachment 1
 - 4) attachment 2 (designated employee contributors form)
- Ecma trademark matters.

Ecma Code of Conduct in patent matters

1.

Ecma considers it is desirable that fullest available information should be disclosed to those selecting technology for Ecma International Standards and those interested in adopting Ecma International Standards¹. Ecma desires to develop standards for which licenses for any essential patents are available on a non-discriminatory basis and on reasonable terms and conditions. Therefore, Ecma desires that any party participating in a technical committee of Ecma International promptly disclose any patent or pending patent application that it believes contain claims that may be required to implement an Ecma International Standard, in accordance with the following provisions.

2.

If an Ecma International Standard is developed and a party may own or control a patent or application with claims that are required to implement such Ecma International Standard, three different situations may arise:

2.1

The patent holder is prepared to grant licenses free of charge to other parties on a non-discriminatory basis on reasonable terms and conditions. Negotiations are left to the parties concerned and are performed outside of Ecma International.

2.2

The patent holder is prepared to grant licenses to other parties on a non-discriminatory basis on reasonable terms and conditions. Negotiations are left to the parties concerned and are performed outside of Ecma International. For patented technology contributed to and incorporated into a Final Draft Ecma International Standard by a patent holder member, the patent holder member may select 2.1 or 2.2. If such patent holder member does not make a selection, 2.2 shall apply.

2.3

For patented technology contributed by a party other than the patent holder, the patent holder is not prepared to comply with the provisions of either Paragraph 2.1 or Paragraph 2.2.

3.

Whatever case applies (2.1, 2.2 or 2.3), the patent holder shall, for patents and pending applications it owns or controls that it believes contains claims that may be required to implement the identified Draft Ecma International Standard, provide a timely written statement to be filed with the Ecma Secretary General at the Ecma International Secretariat, using the attached "Patent Statement and Licensing Declaration Form for an Ecma International Standard" (the "Form" available [here](#)). Any licensing commitment selected will only apply to those claims that end up being required to implement the Final Ecma International Standard.

3.1

In the event the patent holder selects per Paragraph 2.1 and 2.2, the patent holder may identify specific patents associated with box 1 or box 2 of the Form. If an Ecma member does not identify specific patents on the list, the designated licensing commitment will apply to all of the Ecma member's claims in patents and pending applications it owns or controls that end up being required to implement the finalized Standard. The patent holder may submit multiple Forms to document additional patents, each Form applying to patents associated with one of the boxes. A patent holder may re-designate as follows: Box selections cannot be changed, except that identified patents may be re-designated from box 3 to box 1 or 2, or from box 2 to box 1. For licenses executed before a re-designation, the licensees may continue under the existing license or may request terms in accordance with the re-designation.

3.2

In the event a patent holder selects per Paragraph 2.3, the patent holder must identify the specific patents it owns or controls and believes are required to implement the Ecma Standard in a Form under box 3.

3.3

The Form must not include additional provisions, conditions, or any other clauses that may interpret, restrict or vary the terms of the selected box on the Form.

4.

Pursuant to Article 9 of the Ecma International by-laws, each Final Draft Ecma International Standard to be approved shall be submitted two months ahead of a General Assembly (GA).

4.1

Each Ecma member participating in the development of the proposed standard shall, and other Ecma members may, submit a Form at the latest two weeks before the GA (if the vote occurs at the GA) or the end of the postal voting period (if the vote is by mail), if they own or control any patents or patent applications that they believe are required to implement such standard. For so long as such Standard remains an approved Ecma International Standard, the member will be prepared to grant licenses for its essential claims in patents and patent applications in accordance with Paragraph 2 above. In the event Paragraph 2.3 is selected, a patent license may not be available and the technical committee should explore other options.

4.2

This Policy creates no duty for Ecma members to search for any patents or patent applications at any time. A Member's general licensing commitment shall apply to the claims in any patents or patent applications that are required to implement the Standard even if such patents are acquired by the Member after the Standard is finalized. If Paragraph 2.1 or 2.2 is selected, a commitment attaches to a Standard, then the same commitment would automatically apply to future versions of the Standard if the same implicated patent claims (i) are required for implementation of the revised Standard, and (ii) are

used in a substantially similar manner, to a substantially similar extent, to achieve a substantially similar result as the same patent claims were used in the prior version for which the Member has made a licensing commitment.

4.3

An Ecma member participating in the development of the proposed standard that has not submitted a Form regarding a Final Draft Ecma International Standard within the period mentioned in Paragraph 4.1 is obliged to license any claims in patents or patent applications required to implement the Standard on a reasonable and non-discriminatory basis.

5.

Anybody may disclose, in written form identifying the title and patent information, another party's patents and applications that it reasonably believes may be required to implement an Ecma Standard. Such disclosure is not an assertion that such patents or applications are required for the Ecma Standard, but is provided for informational purposes. The Ecma Secretary General will, as feasible, send a Form to each such potential patent holder. A non-member may submit a Form to the Ecma Secretary General that lists the non-member's patents and applications that it believes may be essential to a draft or final Ecma Standard and select one of the options described above in Paragraph 2.

6.

Ecma International shall not provide legal opinions about evidence, validity or enforceability of patents, or whether a claim is required to implement a standard. Accordingly, in instances where a patent or pending patent application is disclosed to the Ecma Secretary General and it is not subject to a license commitment in accordance with boxes 1 or 2 of the Form, approval and publication of a proposed standard is authorized if 2/3 of the GA by vote in person or via letter ballot, support proceeding with the standard notwithstanding possible uncommitted patent(s) and patent application(s) of Ecma members or non-members. As a condition to proceeding, the Ecma Secretary General must provide notice of all identified and possibly uncommitted patents or patent applications and their disposal (if any) (i) to the voting members at least 10 days before the vote on the standard will be completed and (ii) to the public if and when the standard is published as final.

7.

If a patent or pending patent application, that is not subject to a license commitment in accordance with boxes 1 or 2 of the Form, is disclosed to the Ecma Secretary General after an Ecma International Standard has been approved, the process of Paragraph 6 shall be followed to determine if the standard shall be continued, withdrawn or modified.

You can also check the [old Ecma Code of Conduct in Patent Matters](#) that was valid until 3 December 2009 as well as [the initial Version 1](#) approved in December 2009

¹ Ecma International Standards hereafter means Ecma International Standards as well as Ecma International Technical Reports.

The Ecma list of patent statements can be found [here](#).

Ecma Royalty-Free patent policy extension option

E.1 This is an optional Royalty-Free (RF) extension of the Ecma Code of Conduct in Patent Matters ("Code of Conduct"). Under this RF Policy extension, Ecma International may designate certain Technical Committees (TCs) as "Royalty-Free TC" (RFTC) or Task Groups of an Ecma TC as "Royalty-Free Task Group" (RFTG). As to such RFTCs and RFTGs, this RF Policy shall supplement the Code of Conduct and shall take precedence as to anything in the Code of Conduct to the contrary. References in this RF Policy to "Standards" mean Ecma International Standards and Ecma Technical Reports, and references to "Draft Standards" mean drafts of Standards. When used in this RF Policy, "Affiliates" shall refer to entities that are related as described in 3.2 of the Ecma By-laws. In the text that follows RFTC/RFTG is standing for RFTC and RFTG.

E.2 Designation of an RFTC/RFTG is done by the General Assembly and may only occur prior to formation of such RFTC/RFTG (in other words, a standards development activity may not retroactively be designated as an RFTC/RFTG). If work done elsewhere is brought into an RFTC/RFTG, this RF Policy has no effect on any patent-related matters as to that pre-existing work as such. This RF Policy applies to that work only to the extent that it is included in a Standard resulting from the RFTC/RFTG. For Ecma members not participating in any particular RFTC/RFTG, the Code of Conduct, not this RF Policy, applies to such member with respect to the work of that RFTC/RFTG.

E.3 Participation in RFTC/RFTGs and Registration Form: Participation in each RFTC/RFTG shall be limited to those individuals where each entity on whose behalf the individual participates has submitted a "Registration Form" that includes a royalty-free patent license statement that applies to any patent claims owned or controlled by such entity and its Affiliates that are required to implement (are "Essential" to) any Standards that result from the RFTC/RFTG designated on the Registration Form. The Registration Form shall be subject to the opt-out provisions in this RF Policy. The Registration Form shall state that the submitting entity ("RFTC/RFTG Member Organization") is prepared to grant licenses free of charge to an unrestricted number of applicants on a worldwide, non-discriminatory basis, and under other reasonable terms and conditions to make, use, sell, and import implementations of all Standards that result from the RFTC/RFTG designated on the Registration Form. As to future versions of such Standards, the scope of the patent commitment shall be the same as is described in 4.2 of the Code of Conduct. An RFTC/RFTG Member Organization shall be considered "in" or "a participant in" an RFTC/RFTG from the time of submission of a Registration Form until withdrawal (see E.7), if any. Submission of a Registration Form shall be via a mechanism provided by Ecma International.

E.4 Opt-Out of Identified Patents: An RFTC/RFTG Member Organization may exclude from the royalty-free patent license commitment, via an identification mechanism provided by Ecma International (see E.6.), specific patents and/or patent applications that the RFTC/RFTG Member Organization believes may be or become Essential ("Identified Patents"). This opt-out opportunity must be exercised prior to the end of the corresponding Opt-Out Review Window. The RFTC/RFTG Member Organization may only exclude Identified Patents to the extent that the Essentiality of the patents is due to material that (a) was added to the Draft Standard since the version of the Draft Standard for the previous Opt-Out Review Window (if any; see E.5), and (b) was not material that the RFTC/RFTG Member Organization contributed to the RFTC/RFTG. In this context, "material" refers to the technical substance of what is being specified of the Draft Standard, not to specific words in a document. In other words, the opt-out of Identified Patents only applies to new material added to the Draft Standard since the previous opt-out opportunity and, for clarity, specifically does not apply to minor revisions or editorial changes.

E.5 Opt-Out Review Windows: Each Opt-Out Review Window shall be initiated by Ecma Secretariat in consultation with the TC and RFTG chairs. An Opt-Out Review Window shall apply to one or more particular Draft Standards. An Opt-Out Review Window shall be at least 60 days long. All RFTC/RFTG Member Organizations in an RFTC/RFTG shall be notified of each Opt-Out Review Window prior to the beginning of the period and such notification shall clearly identify the end of the period. Opt-Out Review Windows shall be initiated for each Draft Standard at intervals of no less than 4 months (except with the agreement of all RFTC/RFTG Member Organizations in the corresponding RFTC/RFTG) and no longer than 18 months. There shall be an Opt-Out Review Window for each final version of a Draft Standard, and such window shall be timed such that it ends before the Draft Standard becomes a Standard.

E.6 Opt-Out Patent Information: The opt-out identification mechanism (see E.4) shall require: (a) identification of the Identified Patents; (b) identification of the Standard or Draft Standard; and (c) indication of whether, with respect to such Identified Patents and such Standard (or a Standard resulting from such Draft Standard), the RFTC/RFTG Member Organization (i) is prepared to grant licenses under paragraph 2.2 (RAND terms) of the Code of Conduct, or (ii) is not prepared to grant such licenses.

E.7 Withdrawal from an RFTC/RFTG: Ecma International shall provide a mechanism by which an RFTC/RFTG Member Organization in an RFTC/RFTG can withdraw from the RFTC/RFTG. No participation in the RFTC/RFTG on behalf of a withdrawn RFTC/RFTG Member Organization shall be permitted following such withdrawal (unless the RFTC/RFTG Member Organization rejoins with a corresponding new Registration Form). The patent commitment in the Registration Form of a withdrawn RFTC/RFTG Member Organization: (a) shall continue to apply to material in a Draft Standard (i) for which the corresponding Opt-Out Review Window has ended, and (ii) that the RFTC/RFTG Member Organization has contributed to the RFTC/RFTG; and (b) shall not apply as to other material in a Draft Standard. In addition, after an RFTC/RFTG Member Organization withdraws from the RFTC/RFTG, the Code of Conduct applies to that Ecma member as it does to other non-participating Ecma members.

E.8 Late-Joining and Re-Joining Participants: A Registration Form for an RFTC/RFTG applies to all Draft Standards for all Opt-Out Review Windows prior to such joining, including those that passed before the RFTC/RFTG Member Organization began participation in the RFTC/RFTG. However, an RFTC/RFTG Member Organization may, immediately prior to beginning participation in an RFTC/RFTG, use the opt-out mechanism to opt-out Identified Patents, which shall be effective as to material in Draft Standards in Opt-Out Review

Windows that passed when the RFTC/RFTG Member Organization was not a participant in the RFTC/RFTG. For an RFTC/RFTG Member Organization that has previously withdrawn, the new opt-out shall only apply to material in Draft Standards in Opt-Out Review Windows that passed after that prior withdrawal. A party that joins during an Opt-Out Review Window will have the remainder of that Opt-Out Review Window to exclude a patent or patent application.

The previous Ecma International Royalty-Free Patent Policy Extension Option (valid from June 2015 until December 2018) is available in [html version](#) and in [PDF file](#).

Ecma text copyright policy

Purpose

Ecma publishes specifications which must be covered by an Ecma copyright notice. An Ecma Technical Committee must use, for publishing their specifications, either the default Ecma copyright notice, or the Ecma alternative copyright notice and license after having requested and obtained GA approval to do so.

Default copyright notice

COPYRIGHT NOTICE

© Ecma International

By obtaining and/or copying this work, you (the licensee) agree that you have read, understood, and will comply with the following terms and conditions.

This document may be copied, published and distributed to others, and certain derivative works of it may be prepared, copied, published, and distributed, in whole or in part, provided that the above copyright notice and this Copyright License and Disclaimer are included on all such copies and derivative works. The only derivative works that are permissible under this Copyright License and Disclaimer are:

- (i) works which incorporate all or portion of this document for the purpose of providing commentary or explanation (such as an annotated version of the document),*
- (ii) works which incorporate all or portion of this document for the purpose of incorporating features that provide accessibility,*
- (iii) translations of this document into languages other than English and into different formats and*
- (iv) works by making use of this specification in standard conformant products by implementing (e.g. by copy and paste wholly or partly) the functionality therein.*

However, the content of this document itself may not be modified in any way, including by removing the copyright notice or references to Ecma International, except as required to translate it into languages other than English or into a different format.

The official version of an Ecma International document is the English language version on the Ecma International website. In the event of discrepancies between a translated version and the official version, the official version shall govern.

The limited permissions granted above are perpetual and will not be revoked by Ecma International or its successors or assigns.

This document and the information contained herein is provided on an "AS IS" basis and ECMA INTERNATIONAL DISCLAIMS ALL WARRANTIES, EXPRESS OR IMPLIED, INCLUDING BUT NOT LIMITED TO ANY WARRANTY THAT THE USE OF THE INFORMATION HEREIN WILL NOT INFRINGE ANY OWNERSHIP RIGHTS OR ANY IMPLIED WARRANTIES OF MERCHANTABILITY OR FITNESS FOR A PARTICULAR PURPOSE.

Alternative copyright notice

ALTERNATIVE COPYRIGHT NOTICE AND COPYRIGHT LICENSE

© Ecma International

By obtaining and/or copying this work, you (the licensee) agree that you have read, understood, and will comply with the following terms and conditions.

Permission under Ecma's copyright to copy, modify, prepare derivative works of, and distribute this work, with or without modification, for any purpose and without fee or royalty is hereby granted, provided that you include the following on ALL copies of the work or portions thereof, including modifications:

- (i) The full text of this COPYRIGHT NOTICE AND COPYRIGHT LICENSE in a location viewable to users of the redistributed or derivative work.*
- (ii) Any pre-existing intellectual property disclaimers, notices, or terms and conditions. If none exist, the Ecma alternative copyright notice should be included.*
- (iii) Notice of any changes or modifications, through a copyright statement on the document such as "This document includes material copied from or derived from [title and URI of the Ecma document]. Copyright © Ecma International."*

Disclaimers

THIS WORK IS PROVIDED "AS IS," AND COPYRIGHT HOLDERS MAKE NO REPRESENTATIONS OR WARRANTIES, EXPRESS OR IMPLIED, INCLUDING BUT NOT LIMITED TO, WARRANTIES OF MERCHANTABILITY OR FITNESS FOR ANY PARTICULAR PURPOSE OR THAT THE USE OF THE DOCUMENT WILL NOT INFRINGE ANY THIRD PARTY PATENTS, COPYRIGHTS, TRADEMARKS OR OTHER RIGHTS.

COPYRIGHT HOLDERS WILL NOT BE LIABLE FOR ANY DIRECT, INDIRECT, SPECIAL OR CONSEQUENTIAL DAMAGES ARISING OUT OF ANY USE OF THE DOCUMENT.

The name and trademarks of copyright holders may NOT be used in advertising or publicity pertaining to the work without specific, written prior permission. Title to copyright in this work will at all times remain with copyright holders.

The previous Ecma International text copyright policy (June 2009) is available [here](#).

Ecma policy on submission, inclusion and licensing of software

Purpose

The purpose of this Policy is to provide guidance, rules and procedures relating to the submission, inclusion and licensing of Software that is proposed to be part of an Ecma International Standard.[1] Software in standards may require different copyright licenses than descriptive text in standards. Ecma International owns and licenses the copyright in its Standards via the Ecma International Copyright Disclaimer ("Copyright Disclaimer"). While the Copyright Disclaimer permits anyone to copy a Standard, it does not permit others to modify the Standard (except in limited circumstances) or extract portions of the Standard. Therefore, if a Standard includes software alone or in combination with descriptive text, the permissions granted by the Copyright Disclaimer may be inadequate. For example, the Copyright Disclaimer does not include a grant which would allow the copying and modification of example software from the remainder of a Standard in order to run the example on an actual implementation of the Standard.

Individual and Collaboratively Developed Submissions

The guidance, rules and procedures described herein are applicable to both submissions of Software by individual submitters and submissions of Software that is developed collaboratively by two or more submitters.

Policy

1.1 Definitions

For purposes of the Policy "Software" means imperative or declarative programming instructions in a formally defined language that can be processed by hardware that manipulates data according to such programming instructions. Pseudo Code (defined below) is also considered Software under this Policy.[2] Software may be Normative or Non-Normative. Software is Normative Software where it is required to be implemented in products or services which implement the Standard. Software is Non-Normative Software where it is not required to be implemented in products or services which implement the Standard. Non-Normative Software may include example implementations, software for diagnostic or conformance testing, etc.

Pseudo Code or Descriptive Code means code that is human readable and similar to programming languages but that cannot be directly processed by hardware that manipulates data according to instructions.

1.2 Guidelines and Rules

Ecma International strongly believes that an Ecma International Standard should define requirements and not mandate any specific implementation. This gives implementers the opportunity to differentiate their implementations which, in turn, encourages innovation. Since Normative Software may, in effect, mandate an implementation, the use of Normative Software in Ecma International Standards should be limited to situations where it is necessary to enable interoperability. Ecma International has no objection to the inclusion of Non-Normative Software in Ecma International Standards.

Text contributions included in an Ecma International Standard or Technical Report are licensed by the contributor to Ecma International. The contributor of the text contribution continues to own the copyright in its contribution and Ecma International owns the copyright in the collective work. Software contributions included in an Ecma International Standard or Technical Report are treated the same way. Contributors of the Software continue to own the copyrights in their Software contributions and Ecma International owns, and has the right to enforce, the copyright in the collective work (e.g., the Ecma International Standard that incorporates all text and Software contributions).

Accordingly, if Software is included in an Ecma International Standard, copyrights in such Software must be licensed to Ecma International (at the time the Standard in which it is incorporated becomes a final Ecma International Standard) under a broad license which shall give Ecma International the right to make the Software available pursuant to the copyright license set forth on Exhibit A ("License"). Patent claims on the Software that are required to implement the Standard are subject to the Ecma International Code of Conduct in Patent Matters. See the Ecma Code of Conduct in Patent Matters for information regarding the licensing of patent claims that are required to implement Ecma International standards.

1.3 Procedures

In the event a TC desires to include Software in an Ecma International Standard, the following procedure shall apply.

(1) Software submissions are accepted only when submitted with a properly completed Software Submitter Contribution Form (See Exhibit B) or its equivalent presented on an Ecma International authorized website (including, but not limited to the Ecma International own website). Only one Software Submitter Contribution Form is required to be completed by each Software Submitter for each Standard to which a Software Submitter makes a Software submission and applies to all subsequent software submissions to that Standard (even if the Software Submitter makes multiple Software submissions with respect to that Standard). Each party to a joint Software Submission must complete a Software Submitter Contribution Form

(2) Ecma will provide a license to the Software pursuant to the Software License set forth on Exhibit A if the Software is incorporated in an Ecma International Standard.

(3) The following legend or notice, together with the license, will be prominently displayed on any Ecma International Standard in which Software is included: "SOFTWARE, AS DEFINED IN THE ECMA INTERNATIONAL POLICY ON SUBMISSION, INCLUSION AND LICENSING OF SOFTWARE AVAILABLE AT [<https://www.ecma-international.org/ipr>] ("POLICY"), WHICH IS INCLUDED IN AN ECMA INTERNATIONAL STANDARD SHALL BE MADE AVAILABLE PURSUANT TO THE LICENSE SET FORTH IN EXHIBIT A ("LICENSE") OF THE POLICY.



Available [here](#)

- 1) the exhibit A
- 2) the exhibit B (software submitter contribution form)
- 3) attachment 1
- 4) attachment 2 (designated employee contributors form).



Ecma trademark matters

Ecma International has trademarked some of its standardization related terms, such as:

- Ecma International (logo and text)
- OpenXPS® (in ECMA-388)
- ECMAScript® (e.g. in ECMA-262)
- ProxZzy® (in ECMA-393).

Withdrawn Ecma Standards and Technical Reports

Withdrawn Ecma Standards (not in force, electronically available [here](#))

ECMA-1	6 Bit Input/Output Character Code (March 1963)	
ECMA-2	Subset of ALGOL 60 - ECMALGOL	
ECMA-3	CMC7 Printed Image Specification, 2 nd edition (September 1966)	ISO 1004
ECMA-4	Flow Charts, 2 nd edition (September 1966)	ISO 1028
ECMA-5	Data Interchange on 7 Track Magnetic Tape, 3 rd edition (June 1970)	
ECMA-7	7 Bit Code in Punched Cards (April 1965)	ISO 1113
ECMA-8	Nominal Character Dimensions of the Numeric OCR-A Font, 2 nd edition (January 1977)	ISO 1973-1
ECMA-9	FORTTRAN (April 1965)	ISO/IEC 1539
ECMA-10	Data Interchange on Punched Tape, 2 nd edition (July 1970)	ISO 1113
ECMA-11	Alphanumeric Character Set OCR-B for Optical Recognition, 3 rd edition (March 1976)	ISO 1073-2
ECMA-12	Data Interchange on 9-Track Magnetic Tape at 32 bits per mm (800 bpi), 2 nd edition (June 1970)	ISO/IEC 1863
ECMA-14	Rules for the Definition of 4 Bit Sets Derived from the ECMA 7 Bit Coded Character Set (November 1967)	
ECMA-15	Printing Specifications for Optical Character Recognition, 2 nd edition (August 1975)	ISO 1831
ECMA-16	Basic Mode Control Procedures for Data Communication Systems using the ECMA 7-Bit Code, 2 nd edition (June 1973)	
ECMA-17	Graphic Representation of the Control Characters of the ECMA 7-Bit Coded Character Set for Information Interchange (November 1968)	ISO 2047
ECMA-18	Printing Line Position on OCR Single Line Documents, 2 nd edition (January 1977)	ISO 1831
ECMA-19	Coding of Character Sets for MICR and OCR (June 1969)	ISO 2033
ECMA-20	Implementation of the ECMA 7 Bit Coded Character Set on Punched Cards (June 1969)	ISO 1113
ECMA-21	Character Positioning on OCR Journal Tape (June 1969)	
ECMA-22	Electrical Safety Requirements for Data Processing Machines (June 1969)	
ECMA-23	Keyboards Generating the Code Combinations of the Characters of the ECMA 7-Bit Coded Character Set, 2 nd edition (January 1975)	ISO/IEC 9995
ECMA-24	Code Independent Information Transfer (An extension to the Basic Mode Transmission Control Procedures) (December 1969)	
ECMA-25	Representation of 8-Bit combinations on 12-Row Punched Cards (June 1970)	ISO 6586
ECMA-26	Recovery Procedures (An Extension to the Basic Mode Control Procedures for Data Communication Systems) (April 1971)	

ECMA-27	Abort and Interrupt Procedures (An Extension of the Basic Mode Control Procedures for Data Communication Systems) (April 1971)	
ECMA-28	Multiple Station Selection Procedures (An Extension of the Basic Mode Control Procedures for Data Communication Systems) (April 1971)	
ECMA-29	Conversational Information Transfer (An Extension of the Basic Mode Control Procedures for Data Communication Systems) (September 1971)	
ECMA-30	OCR B Subsets for Numeric Applications, 2 nd edition (March 1976)	
ECMA-31	Mechanical Safety Requirements for DTA Processing Machines (September 1971)	
ECMA-32	Mechanical, Physical and Magnetic Characteristics of Interchangeable 6-Disk Packs (September 1971)	
ECMA-33	Track Format Characteristics of Interchangeable 6-Disk Packs (September 1971)	ISO 3561
ECMA-34	Data Interchange on 3,81 mm Magnetic Tape Cassette (63 ftpmm, Phase Encoded at 32 bpmm), 3 rd edition (September 1976)	ISO 3407
ECMA-36	Data Interchange on 9-Track Magnetic Tape at 63 bpmm (1600 bpi) Phase-Encoded (December 1971)	ISO/IEC 3788
ECMA-37	Supplementary Transmission Control Functions (An Extension of the Basic Mode Control Procedures for Data Communication Systems) (June 1972)	
ECMA-38	Mechanical, Physical and Magnetic Characteristics of Interchangeable Single Disk Cartridges (Top Loaded) (September 1973)	ISO 3562
ECMA-39	Track Format Characteristics of Interchangeable Single Disk Cartridges (Top Loaded) (September 1973)	ISO 3563
ECMA-40	High-Level Data Link Control Procedures (HDLC) - Frame Structure, 3 rd edition (January 1980)	ISO/IEC 3309
ECMA-41	Magnetic Tape Cassette Labelling and File Structure for Information Interchange (December 1973)	ISO 4341
ECMA-42	Alpha-numeric Character Set for 7x9 Matrix Printers (December 1973)	
ECMA-44	Implementation of the ECMA 7-Bit and 8-Bit Coded Character Sets on Punched Cards (September 1975)	ISO 6586
ECMA-45	Data Interchange on Magnetic 12-Disk Packs (100 Mbytes) (September 1975)	ISO 4337
ECMA-46	Data Interchange on 6,30 mm Magnetic Tape Cartridge (63 bpmm, Phase Encoded) (March 1976)	ISO 4057
ECMA-47	Limits and Measurements Methods for Radio Interference from EDP Units (March 1976)	
ECMA-49	HDLC-Elements of Procedure, 2 nd edition (August 1979)	ISO/IEC 4335
ECMA-50	Programming Language PL/1 (December 1976)	ISO 6160
ECMA-51	Implementation of the Numeric OCR-A Font with 9x9 Matrix Printers (January 1977)	
ECMA-52	Magnetic 12-Disk Packs (200 Mbytes) (September 1977)	
ECMA-53	Representation of Source Programs for Program Interchange - APL, COBOL, FORTRAN, Minimal BASIC and PL/1 (January 1978)	ISO 5653

ECMA-54	Data Interchange on 200 mm Flexible Disk Cartridges using Two-Frequency Recording at 13 262 ftprad on One Side, 2 nd edition (January 1982)	ISO 5654
ECMA-55	Minimal BASIC (January 1978)	ISO 6373
ECMA-56	Self-Loading Cartridges for 12,7 mm Wide Magnetic Tapes (September 1978)	ISO 6098
ECMA-57	Safety Requirements for Data Processing Equipment, 2 nd edition (September 1981)	
ECMA-58	Flexible Disk Cartridge Labelling and File Structure for Information Interchange, 2 nd edition (January 1981)	
ECMA-59	Data Interchange on 200 mm Flexible Disk Cartridges using Two-Frequency Recording at 13 262 ftprad on Both Sides (August 1979)	ISO 5654-1
ECMA-60	HDLC-Unbalanced Class of Procedure (August 1979)	ISO/IEC 7809
ECMA-61	HDLC-Balanced Class of Procedure (August 1979)	ISO/IEC 7809
ECMA-62	Data Interchange on 12,7 mm 9-Track Magnetic Tape - 32 ftpmm, NRZ1, 32 cpmm - 126 ftpmm, Phase Encoding, 63 cpmm - 356 ftpmm, NRZ1, 246 cpmm GCR, 2 nd edition (March 1985) (for reference see also ISO 1863, ISO 3788 and ISO 5652)	ISO 1864
ECMA-63	Representation of Numerical Values in Character Strings for Information Interchange (September 1980)	
ECMA-64	Magnetic Disk for Data Storage Devices, 160 000 Flux Transitions per Track, 356 mm Diameter, 2 nd edition (September 1982)	ISO 6901
ECMA-65	Magnetic Disk for Data Storage Devices, 107 500 Flux Transitions per Track, 266 mm and 356 mm Diameter (September 1980)	ISO 6902
ECMA-66	Data Interchange on 130 mm Flexible Disk Cartridges using Two-Frequency Recording at 7 958 ftprad on One Side (September 1980)	ISO 6596
ECMA-67	130 mm Flexible Disk Cartridge Labelling and File Structure (January 1981)	
ECMA-68	Reels for 12,7 mm Wide Magnetic Tapes (Sizes 16, 18 and 22) (January 1981)	ISO 8064
ECMA-69	Data Interchange on 200 mm Flexible Disk Cartridges using MFM Recording at 13 262 ftprad on Both Sides (January 1981)	ISO 7065
ECMA-70	Data Interchange on 130 mm Flexible Disk Cartridges using MFM Recording at 7 958 ftprad on 40 Tracks on Each Side, 2 nd edition (June 1986)	ISO 7487
ECMA-71	HDLC Selected Procedures (January 1981)	ISO/IEC 3309 & 4335
ECMA-72	Transport Protocol, 3 rd edition (March 1985)	ISO/IEC 8073
ECMA-73	Magnetic Disk for Data Storage Devices 95 840 Flux Transitions per Track, 200 mm Outer Diameter, 63,5 mm Inner Diameter, 2 nd edition (September 1982)	ISO 7297
ECMA-75	Session Protocol (January 1982)	ISO 8327
ECMA-76	Magnetic Disk for Data Storage Devices, 158 000 Flux Transitions per Track, 210 mm Outer Diameter, 100 mm Inner Diameter (September 1982)	ISO 7298
ECMA-77	Magnetic Disk for Data Storage Devices, 83 000 Flux Transitions per Track, 130 mm Outer Diameter, 40 mm Inner Diameter (September 1982)	ISO 7929

ECMA-78	Data Interchange on 130 mm Flexible Disk Cartridges using MFM Recording at 7 958 ftprad on 80 Tracks on Each Side, 2 nd edition (June 1986)	ISO 8378
ECMA-79	Data Interchange on 6,30 mm Magnetic Tape Cartridge using IMFM Recording at 252 ftpmm, 2 nd edition (September 1985)	ISO 8063
ECMA-80	Local Area Networks (CSMA/CD Baseband) Coaxial Cable System, 2 nd edition (March 1984)	
ECMA-81	Local Area Networks (CSMA/CD Baseband) Physical Layer, 2 nd edition (March 1984)	ISO/IEC 8802-3
ECMA-82	Local Area Networks (CSMA/CD Baseband) Link Layer, 2 nd edition (March 1984)	ISO/IEC 8802-3
ECMA-83	Safety Requirements for DTE-to-DCE Interface in Public Data Networks, 2 nd edition (September 1985)	
ECMA-84	Data Presentation Protocol (September 1982)	ISO/IEC 8823-1
ECMA-85	Virtual File Protocol (September 1982)	
ECMA-86	Generic Data Presentation - Services Description and Protocol Definition (March 1983)	ISO/IEC 8822
ECMA-87	Generic Virtual Terminal - Service and Protocol Description (March 1983)	ISO 9040
ECMA-88	Basic Class Virtual Terminal - Service Description and Protocol Definition (March 1983)	ISO 9040 & 9041
ECMA-89	Local Area Networks - Token Ring Technique, 2 nd edition (March 1985)	ISO/IEC 8802-5
ECMA-90	Local Area Networks - Token Bus Technique (September 1983)	ISO/IEC 8802-4
ECMA-91	Flexible Disk Cartridges - File Structure and Labelling for Information Interchange (March 1984)	ISO 7665
ECMA-92	Connectionless Internetwork Protocol (March 1984)	
ECMA-93	Distributed Application for Message Interchange (MIDA) (September 1984)	
ECMA-95	Limits of Interference and Measurement Methods (March 1985)	
ECMA-96	Syntax of Graphical Data for Multiple-Workstation Interface (GDS) (September 1985)	
ECMA-97	Local Area Networks - Safety Requirements, 2 nd edition (December 1992)	
ECMA-98	Data Interchange on 6,30 mm Magnetic Tape Cartridge using NRZ1 Recording at 394 ftpmm - Streaming Mode (September 1985)	ISO 8462
ECMA-101	Open Document Architecture (ODA) and Interchange Format, 2 nd edition (December 1988)	ISO 8613
ECMA-102	Rate Adaptation for the Support of Synchronous and Asynchronous Equipment using the V. Series Type Interface on a PCSN, 2 nd edition (July 1987)	
ECMA-103	Physical Layer at the Basic Access Interface between Data Processing Equipment and Private Switching Networks, 2 nd edition (December 1987)	
ECMA-104	Physical Layer at the Primary Rate Access Interface between Data Processing Equipment and Private Switching Networks (September 1985)	

ECMA-105	Data Link Layer Protocol for the D-Channel of the Interfaces at the Reference Point between Terminal Equipment and Private Telecommunication Networks, 4 th edition (June 1993)	I-ETS 300 169
ECMA-110	Ergonomics - Requirements for Monochromatic Visual Display Devices (December 1985)	
ECMA-111	Small Computer System Interface – SCSI (December 1985)	
ECMA-112	X.25 (1980) Subnetwork-Dependent Convergence Protocol (December 1985)	
ECMA-115	Common Secondary Keyboard Layout for Languages using a Latin Alphabet (June 1986)	
ECMA-116	BASIC (June 1986)	
ECMA-117	Domain Specific Part of Network Layer Addresses (June 1986)	
ECMA-122	MIDA, Mailbox Service Description and Mailbox Access Protocol Specification (July 1987)	
ECMA-123	In Band Parameter Exchange in Private Pre-ISDN Networks using Standard ECMA-102, 2 nd edition (June 1990)	
ECMA-124	Designation of Unrecorded Flexible Disk Cartridges (December 1987)	
ECMA-126	Ergonomics - Requirements for Colour Visual Display Devices (December 1987)	
ECMA-127	Remote Procedure Call (RPC) using OSI, 2 nd edition (June 1990)	
ECMA-129	Information Technology Equipment - Safety, 2 nd edition (April 1994)	IEC 950
ECMA-131	Referenced Data Transfer (July 1988)	
ECMA-132	Method for Measuring Printer Throughput, 2 nd edition (June 1991)	ISO 10561
ECMA-134	Method for the Specification of Basic and Supplementary Services of Private Telecommunication Networks (April 1989)	ETS 300 387
ECMA-135	Scenarios for Interconnections Between Exchanges of Private Telecommunication Networks (April 1989)	
ECMA-136	Ergonomics - Requirements for Non-CRT Visual Display Units (June 1989)	
ECMA-137	Document Filing and Retrieval Application (December 1989)	ISO 10166
ECMA-138	Security in Open Systems - Data Elements and Service Definitions (December 1989)	
ECMA-140	Document Printing Application (DPA) (June 1990)	ISO/IEC 10175
ECMA-141	Private Telecommunication Networks (PTN) - Inter-Exchange Signalling - Data Link Layer Protocol (PTN QSIG-L2), 2 nd edition (June 1993)	I-ETS 300 170
ECMA-166	Information Technology Equipment - Routine Electrical Safety Testing in Production (June 1992)	EN 50116
ECMA-172	Procedure for Measurement of Emissions of Electric and Magnetic Fields from VDUs from 5 Hz to 400 kHz (June 1992)	
ECMA-181	Uncertainty of Measurement as Applied to Type Approval of Products (December 1992)	

ECMA-187	ODA-API - Application Profile Interface for Handling Compound Documents (June 1993)	
ECMA-199	Immunity of VDUs to Power Frequency Magnetic Fields (December 1993)	
ECMA-200	Immunity of Information Technology Equipment to Lightning Surges (December 1993)	
ECMA-204	Private Telecommunication Networks (PTN) - Inter-Exchange Signalling Protocol - Supplementary Service Interactions (QSIG-IA) (December 1993)	ETS 300 427
ECMA-215	Private Integrated Services Network (PISN) - Cordless Terminal Mobility (CTM) - Inter-Exchange Signalling Protocol - Cordless Terminal Incoming Call Additional Network Feature (QSIG-CTMI), 2 nd edition (September 1997)	ETS 300 696
ECMA-216	Private Integrated Services Network (PISN) - Cordless Terminal Mobility (CTM) - Inter-Exchange Signalling Protocol - Cordless Terminal Location Registration Supplementary Service (QSIG-CTLR), 2 nd edition (September 1997)	ETS 300 693
ECMA-227	Portable Common Tool Environment (PCTE) - Extensions for Support of Fine-Grain Objects - Abstract Specification (October 1995)	
ECMA-228	Portable Common Tool Environment (PCTE) - Extensions for support of Fine-Grain Objects - C Programming Language Binding (October 1995)	
ECMA-229	Portable Common Tool Environment (PCTE) - Extensions for Support of Fine-Grain Objects - Ada Programming Language Binding (October 1995)	
ECMA-233	Private Integrated Services Network (PISN) - Cordless Terminal Mobility (CTM) - Inter-Exchange Signalling Protocol - Cordless Terminal Outgoing Call Additional Network Feature (QSIG-CTMO), 2 nd edition (September 1997)	I-ETS 300 808
ECMA-237	Limits and Methods of Measurement of Immunity Characteristics of Information Technology Equipment (June 1996)	
ECMA-243	Private Integrated Services Network (PISN) - Cordless Terminal Mobility (CTM) - Inter-Exchange Signalling Protocol - Cordless Terminal Authentication Supplementary Services (QSIG-CTAU), 2 nd edition (September 1997)	I-ETS 300 809
ECMA-255	Portable Common Tool Environment (PCTE) - Object Orientation Extensions - Abstract Specification (December 1996)	
ECMA-256	Portable Common Tool Environment (PCTE) - Object Orientation Extensions - C Programming Language Binding (December 1996)	
ECMA-257	Portable Common Tool Environment (PCTE) - Object Orientation Extensions - Ada Programming Language Binding (December 1996)	
ECMA-290	ECMAScript® Components Specification (June 1999)	
ECMA-327	ECMAScript® 3rd edition Compact Profile (June 2001)	
ECMA-357	ECMAScript® for XML (E4X) Specification, 2nd edition (December 2005)	ISO/IEC 22537

**Withdrawn Ecma Technical Reports
(not in force, electronically available [here](#))**

ECMA TR/1	A Set of I/O Procedures for ECMALGOL (January 1967)
ECMA TR/2	Formal Definition of the Syntax of COBOL (September 1970)
ECMA TR/3	Continuous Sprocket Punched Stationery Part II (Physical Properties, Fastenings, Packaging and Storage) (March 1972)
ECMA TR/4	Continuous Stationery in Roll Form (June 1972)
ECMA TR/5	Suggestions for a Disk Labelling System (June 1972)
ECMA TR/6	Recommended Sizes of Forms for Optical Reading (June 1972)
ECMA TR/7	Continuous Sprocket-Punched Stationery Part I (Recommended Sizes) (December 1973)
ECMA TR/8	Recommended OCR Paper Specifications, 2 nd edition (January 1977)
ECMA TR/9	Safety Requirements for Data Processing Equipment (January 1978)
ECMA TR/10	Listing of Software Names, 2 nd edition (March 1982)
ECMA TR/11	Guidelines for Magnetic Tape Handling and Storage (January 1981)
ECMA TR/12	Radio Interference from DP/OE Limits and Measurement Methods (September 1982)
ECMA TR/13	Network Layer Principles (September 1982)
ECMA TR/14	Local Area Networks - Layers 1 to 4 Architecture and Protocols (September 1982)
ECMA TR/15	Analysis of European X.25 Networks (September 1983)
ECMA TR/16	Interface Characteristics for a DTE to Operate with European Rec.X.25 Networks (September 1983)
ECMA TR/17	Permission to Connect - PTT Requirements for Obtaining Approval to Connect Apparatus to the Network (September 1983)
ECMA TR/19	Local Area Networks - Safety Requirements (March 1984)
ECMA TR/20	Layer 4 to 1 Addressing (March 1984)
ECMA TR/21	Local Area Networks - Interworking Units for Distributed Systems (March 1984)
ECMA TR/22	Ergonomics - Recommendations for VDU Work Places (March 1984)
ECMA TR/23	Electrostatic Discharge Susceptibility (September 1984)
ECMA TR/24	Interface between Data Processing Equipment and Private Automatic Branch Exchange (March 1985)
ECMA TR/25	OSI Sub-Network Interconnection Scenarios Permitted within the Framework of the ISO-OSI Reference Model (March 1985)
ECMA TR/26	Planning and Installation Guide for CSMA/CD 10 MBit/s Baseband Local Area Networks, 2 nd edition (June 1990)
ECMA TR/28	Safety Verification (Save) Report ECMA-57/IEC 435 (September 1985)
ECMA TR/29	Open Systems Interconnection Distributed Interactive Processing Environment (DIPE) (September 1985)
ECMA TR/30	Remote Database Access Service and Protocol (December 1985)
ECMA TR/31	Remote Operations - Concepts, Notation and Connection-Oriented Mappings (December 1985)
ECMA TR/32	OSI Directory Access Service and Protocol (December 1985)
ECMA TR/34	Maintenance at the Interface Between Data Processing Equipment and Private Switching Network (June 1986)
ECMA TR/35	Particular Safety Requirements for Equipment to be Connected to Telecommunication Networks (December 1986)

ECMA TR/37	Framework for OSI Management (December 1986)
ECMA TR/38	End System Routing (December 1986)
ECMA TR/39	Compliance Verification (COVER) Report, 3 rd edition (December 1992)
ECMA TR/40	Electrostatic Discharge Immunity Testing of Information Technology Equipment (July 1987)
ECMA TR/41	ODA - Document Specification Language (July 1987)
ECMA TR/42	Framework for Distributed Office Application (July 1987)
ECMA TR/43	Packetized Data Transfer in Private Switching Networks (December 1987)
ECMA TR/44	An Architectural Framework for Private Networks, 2 nd edition (December 1989)
ECMA TR/45	Information Interchange for Remote Maintenance at the DPE-to-PSN Interface (December 1987)
ECMA TR/47	Configuration Management Service Definition (July 1988)
ECMA TR/48	Study of the Translation of the ODA Formatted Form into Page Description Languages (December 1988)
ECMA TR/49	Support Environment for Open Distributed Processing (December 1989)
ECMA TR/50	Inter-Domain Intermediate System Routeing (December 1989)
ECMA TR/51	Requirements for Access to Integrated Voice and Data Local and Metropolitan Area Networks (June 1990)
ECMA TR/52	Computer Supported Telecommunications Applications (June 1990)
ECMA TR/54	A Management Framework for Private Telecommunication Networks (December 1990)
ECMA TR/56	Information Technology Equipment - Recommended Measuring Method for Ozone Emission (June 1991)
ECMA TR/60	Supplementary Services and Additional Network Features in Private Telecommunication Networks (June 1992)
ECMA TR/63	Alphabetical Reference Index to IEC 950, 3 rd edition (December 1995)
ECMA TR/65	PTNX Functions for the Utilization of Intervening Networks in the Provision of Overlay Scenarios (Transparent Approach) - General Requirements (TR/Mapping) (June 1994)
ECMA TR/89	Common Language Infrastructure (CLI) - Common Generics, 2 nd edition (June 2006)

History of Ecma International

By 1959 the growing use of computers, built by several different manufacturers, showed the necessity for standardization in operational techniques, such as programming, and also input and output codes.

Such standards would make it possible to use data prepared for, or even by, a computer made by one manufacturer to be on a computer made by another with the minimum of alteration. Also it would avoid duplication of work in the preparation of, for example, programming languages by several manufacturers.

Though certain National Bodies had, before 1960, started work on standards in this field, e.g. paper tape and codes, there did not appear to be collaboration between them, nor between the manufacturers themselves. Different countries may have different requirements, so that it may not be necessary to have the same standards everywhere, but the standards should at least be compatible.

With the object of co-ordinating such work, the Heads of the Companies of longest standing in Europe in the data processing field (Compagnie des Machines Bull, IBM World Trade Europe Corporation and International Computers and Tabulators Limited) sent a joint letter to all the known computer manufacturers within Europe, inviting these companies to send representatives to a meeting.

This meeting was held on April 27, 1960, in Brussels; it was decided that an association of manufacturers should be formed which would be called **European Computer Manufacturers Association** or for short ECMA, and a Committee was nominated to prepare the formation of the Association and to draw up By-laws and Rules.

By December 1960 the form that the Association would take was fairly well defined and it had been decided that the headquarters should be in Geneva to be near the headquarters of the International Organization for Standardization and the International Electrotechnical Commission. On 17th May 1961, the Association officially came into being and all those Companies which attended the original meeting became members. The constituent assembly was held on 17th June 1961.

Just prior to the official registration of Ecma, it was invited to be represented at a Round-Table Conference to be held in Geneva organized by ISO and IEC to discuss standardization in the general field of computers. This meeting resulted in the formation of TC97 and in the organization of its own Working Groups, and Ecma was asked to become a liaison member.

In 1987, when TC97 became part of ISO/IEC JTC 1, Ecma became A-liaison member of JTC 1.

To reflect the global activities of the Europe-based Ecma organization the name was changed in 1994 to: **Ecma International - European association for standardizing information and communication systems.**

Though before 1994, ECMA was known as "European Computer Manufacturers Association", after 1994, when the organization became global, the "trademark" "Ecma" was kept for historical reasons.



Ecma Fellow award

The Ecma Fellow award recognizes selected Ecma individuals who have served Ecma for a long time in an exceptionally outstanding fashion. Ecma grants those individuals the status of Ecma Fellow who, if they choose to, would be able at no cost continue to participate in Ecma work as Emeritus members. The Ecma Fellow award and Emeritus membership policy is available [here](#).

Fellows awarded in 2019

Donald Baines

for his significant contributions to the development of Ecma acoustics Standards.

Kei Yamashita

for his leadership and outstanding contributions to the development of Ecma Standards.

Fellows awarded in 2018

Brendan Eich

for his leadership in the creation of the ECMAScript® (JavaScript™) standard and for his outstanding contributions to the development of the ECMAScript® Standard.

Allen Wirfs-Brock

for major contributions and his active participation to the development of the ECMAScript® Standard.

Past Presidents / Secretaries General

Past Presidents

1961-1962

C. G. Holland-Martin (ICT)

1963-1964

J. Engelfriet (EL)

1965-1966

M. R. Pedretti (IBM)

1967-1968

J. M. M. Pinkerton (ICL)

1969-1970

P. J. Davous (Bull)

1971-1972

K. Scheidhauer (AEG-Tfk)

1973-1974

J. M. M. Pinkerton (ICL)

1975

J. van Eijbergen (Philips)

1976-1977

W. Heimann (Siemens)

1978-1979

M. H. Johnson (Ferranti)

1980-1981

J. van Eijbergen (Philips)

1982-1983

H. Feissel (Cii HB)

1984-1985

J. Scherpenhuizen (Digital)

1986-1987

C. Rossetti (STET)

1988-1989

J. Dubos (Bull)

1990

Jan van den Beld (Philips)

1991-1992

Gerhard Habertzettl (Siemens Nixdorf)

1993-1994

Werner Brodbeck (IBM)

1995-1996

Dieter Gann (HP)

1997-1998

P.A. Trudgett (BT)

1999-2000

Malcolm Bermange (Xerox)

2001-2002

Peter Hofmann (IBM)

2003-2004

Stan Statt (Intel)

2005-2006
Harald Theis (Avaya)

2007-2008
John Neumann (Toshiba)

2009-2010
Paul Weijenbergh (Philips)

2011-2012
Josée Auber (HP)

2013-2014
Isabelle Valet-Harper (Microsoft)

2015-2017
Kei Yamashita (Hitachi)

2018-2019
Jochen Friedrich (IBM)

2020-2021
Isabelle Valet-Harper (Microsoft)

2022-2024
Jochen Friedrich (IBM)

Past Secretaries General

1961-1991
Dara Hekimi († 18/02/2002)

1992-2007
Jan van den Beld

2007-2019
István Sebestyén

2019-2023
Patrick Lüthi



About the Ecma Mementos

The Ecma Mementos are the Annual Reports of Ecma International. They aim to provide comprehensive overview about the activities of Ecma International, its working rules, its membership and more.

The first Ecma Memento was published in 1962.

The current and past Ecma Mementos can be downloaded [here](#).

Ecma privacy policy

The current Ecma privacy policy can be found on the Ecma website (<https://ecma-international.org/policies/privacy-policy/>)